

GEOG-505



GEOG-505 FUNDAMENTALS OF CARTOGRAPHY

M.A./M.Sc. 1st Semester



**DEPARTMENT OF GEOGRAPHY AND NATURAL RESOURCE
MANAGEMENT**

**SCHOOL OF EARTH AND ENVIRONMENT SCIENCE
UTTARAKHAND OPEN UNIVERSITY**

(Teenpani Bypass, Behind Transport Nagar Haldwani (Nainital)Uttarakhand

M.A /M.Sc GEOG - 505

FUNDAMENTALS OF CARTOGRAPHY



**DEPARTMENT OF GEOGRAPHY AND NATURAL RESOURCE
MANAGEMENT**

**SCHOOL OF EARTH AND ENVIRONMENT SCIENCE
UTTARAKHAND OPEN UNIVERSITY**

Phone No. 05946-261122, 261123

Toll free no. 18001804025

Fax no. 05946-164232, E. Mail info@uou.ac.in

Website: <https://uou.ac.in>

M.A /M.Sc GEOG - 505

FUNDAMENTAL OF CARTOGRAPHY



Board of Studies

Chairman	Convener
Vice Chancellor Uttarakhand Open University, Haldwani	Professor P.D. Pant School of Earth and Environment Science Uttarakhand Open University, Haldwani
Professor R.K. Pande (Retd) Head & Dean, Department of Geography DSB Campus, Nainital	Professor Subhakanta Mohapatra Head, Department of Geography IGNOU, New Delhi
Professor Simrit Kahlon Department of Geography Panjab University, Chandigarh	Dr. Ranju Joshi Pandey Department of Geography & NRM School of Earth, and Environment Science Uttarakhand Open University, Haldwani
Dr. Pradeep Kumar Pant Department of Geography & NRM School of Earth and Environment Science Uttarakhand Open University, Haldwani	Mr. Sudhanshu Verma Department of Geography & NRM School of Earth and Environment Science Uttarakhand Open University, Haldwani

Programme Coordinator

Dr. Ranju Joshi Pandey
Department of Geography and Natural Resource Management
School of Earth and Environment Science
Uttarakhand Open University, Haldwani

Unit Writers

S.No.	Unit Written By	Unit No.
1.	Dr. Taruna Bansal Associate Professor Jamia Millia Islamia University, New Delhi	1 & 4
2.	Dr. Pradeep Kumar Pant Assistant Professor School of Geography Uttarakhand Open University, Haldwani	2 & 3

Title	: Practical
ISBN	:
Copyright	: Uttarakhand Open University
Edition	: first (2023)

Published By : Uttarakhand Open University, Haldwani, Nainital-263139

Printed By :

CONTENTS

PAGE NO.

BLOCK- CARTOGRAPHIC REPRESENTATION OF GEOGRAPHICAL DATA

UNIT-1 CARTOGRAPHY, NATURE, SCOPE & DEVELOPMENT, MAPS. TYPES & THEIR FUNCTION, MAP AS A TOOL OF ANALYSIS AND SYNTHESIS.	1-24
UNIT-2 RELIEF MAP AND DIAGRAM: DEPICTION OF RELIEF, SLOP, AND GRADIENT, PROFILE, METHODS OF SLOP ANALYSIS (E.G. WENTWORTH, SMITH) AND ALTIMETRY FREQUENCY CURVE	25-50
UNIT-3 CLIMATE MAPS AND DIAGRAMS: CLIMATE MAPS AND DIAGRAMS, REPRESENTATION OF CLIMATE DATA: ISOPLETHS, COLUMNAR DIAGRAM, WIND ROSE DIAGRAMS, RAINFALL DISPERSAL, HYTHERGRAPH AND CLIMOGRAPH.	51-74
UNIT-4 CARTOGRAPHIC REPRESENTATION OF SOCIO-ECONOMIC DATA	75-106

BLOCK 1: CARTOGRAPHIC REPRESENTATION OF GEOGRAPHIC DATA

UNIT- 1 CARTOGRAPHY: NATURE, SCOPE AND DEVELOPMENT, MAPS: TYPES AND THEIR FUNCTION, MAP AS A TOOL OF ANALYSIS AND SYNTHESIS

1.1 OBJECTIVES

1.2 INTRODUCTION

1.3 CARTOGRAPHY

1.3.1 DEFINITION OF CARTOGRAPHY

1.3.2 NATURE AND SCOPE OF CARTOGRAPHY

1.3.3 BRANCHES OF CARTOGRAPHY

1.3.4 DEVELOPMENT OF CARTOGRAPHY

1.4 MAPS

1.4.1 TYPES OF MAPS

1.4.2 FUNCTION OF MAPS

1.4.3 MAP AS A TOOL OF ANALYSIS AND SYNTHESIS

1.5 SUMMARY

1.6 GLOSSARY

1.7 ANSWERS TO CHECK YOUR PROGRESS

1.8 REFERENCES

1.9 TERMINAL QUESTIONS

1.1 OBJECTIVES

After having the detailed study of this unit you will be able to

- Know cartography, nature, scope, and development
- Understand the maps and their function
- Understand the map as a tool of communication, analysis, and synthesis

A map is a creative act of visual communication. The map's composition, choice of symbols and colours, and map content compilation require thoughtful consideration to transfer the map's message. Different kinds of symbols and colours need to be arranged and composed carefully to generate a readable map that clearly expresses the map content and message. Before starting the process of map designing, it is necessary to review the following questions:

What are the purpose, message, and central aspect of the map?

Who is the map aimed at?

Who will be using the map?

How will the reader use the map (i.e., office, field)?

And, to answer these questions, you have to understand how maps are drawn? The art and science of mapmaking in a common language known as cartography. In the next section, you will be able to understand what cartography is, its nature, scope, and development over time.

1.2 INTRODUCTION

In this unit, you will learn about what is meant by cartography, its nature, and its scope. Cartography can be defined as the art and science of mapmaking. **Mapping** is the visual communication of spatial information on a piece of paper. A map is drawn at a reduced scale because it is impractical to show all the Earth's surface features on a plain sheet of paper. This unit will explain the various definitions of cartography and focus on how cartography has developed over time. In the present unit, we will also study types of maps, their function, and map as a tool of analysis and synthesis.

1.3 CARTOGRAPHY

In simple words, cartography can be defined as the art, science, and technology of mapmaking. The term cartography has derived from two words –the *French* word *cart* meaning *map* and a *Greek* word *graffiti* meaning *writing*. In simple words, it is a unique set of transformations that involve the creation and manipulation of visual and virtual information, commonly in the form of maps. Therefore, it can be referred to as the science of visual communication. A cartographer can present scientific and artistic skills for the production of a good map. The origin of cartography is as old as the history of art when man started to move from one place to another and recorded his travel experience in pictorial form.

The field of cartography has been dynamic as the process involved drawing maps on a piece of paper rather than focusing on other aspects of it such as capturing data, manipulating, processing, and displaying. Cartography has evolved over the decades, and traditional methods have been replaced with modern cartographic techniques and tools. These developments have given a new insight to cartographers for the handling of geospatial information. The obsolete process of mapmaking has been replaced with digital mapping and manipulation of data due to ever-changing technological advancement.

1.3.1. DEFINITIONS OF CARTOGRAPHY

Different scholars and associations have given various definitions. A few of them are listed below to understand the nature and scope of cartography.

International Cartographic Association (1992) defines "Cartography as the discipline dealing with the conception, production, dissemination, and study of maps. Cartography is also about representation- the map. This means that cartography is the whole process of mapping".

International Cartographic Association (1973) states that "Cartography is the art, science, and technology of making maps, together with their study as science documents and works of art.

According to **Robinson (1969)**, "Cartography is a meeting place of science and art. It employs a scientific method in the form of logic and reason to construct its products – the maps."

United Nations (1949) believes that "Cartography is the science of preparing all types of maps and charts and includes every operation from original survey to the final printing of maps."

Cartography is the art and science of graphically representing a geographical area, usually on a flat surface such as a map or chart. It involves the superimposition of political, cultural, or other non-geographical aspects on a geographical area represented on the map (**Britannica Encyclopedia**).

1.3.2 NATURE AND SCOPE OF CARTOGRAPHY

Cartography as a field is dynamic, and the thrust of this field relies on mapmaking. Cartography or mapmaking is the combination of both artistic and graphical representation of artefacts/maps. In cartography, the spatial information can be represented with cartographic tools and techniques as it explores, manipulates, analyses, and visualizes the information related to space. The process, practice, skill, and study of making a map are known as cartography in simple words.

The process involves collecting data, designing, processing, drawing, printing, and marketing maps. On a different level of mapmaking, several people are involved in the creation of a map. Cartography serves the cartographers or map users' need for a map to acquire information for various purposes. Distorted or error in maps can influence map users to make wrong decisions and manage resources and planning process. A good map helps in making better decisions, communication, and interpretation of information. Thus, you have to understand that cartography is like a drama played by two actors- one, the mapmaker, and the other being the map-user (Figure 1.1). The mapmaker needs to select the right information and put it in a proper map format to deliver the information to the map-user. The entire process involves the following four methods –

- i. Collection and selection of data
- ii. Data generalization, map designing, and construction
- iii. Reading or viewing the map
- iv. Interpretation of the information gathered from the map.

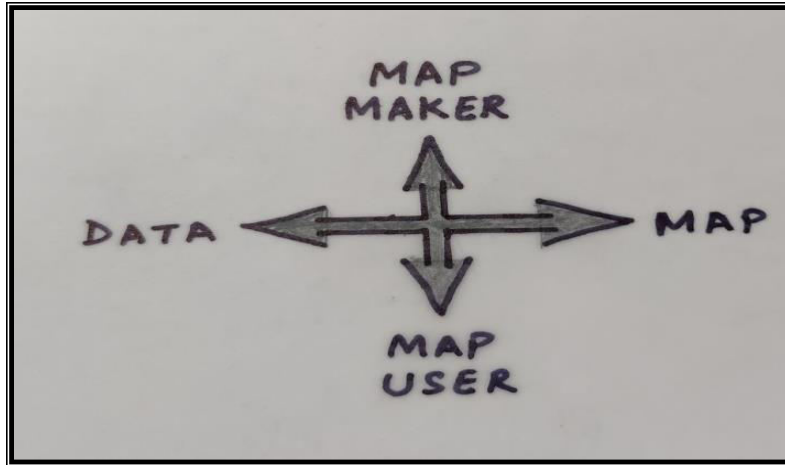

Fig. 1.1 Relationship between mapmaker and the Map user

From ancient times to the present-day, maps have proved to be the best way to visualize geospatial data. They have facilitated the collecting, manipulating, and analysis of the spatial issues of the world. The maps' size may vary from small postage stamps, charts, plans, and globes to bigger wall maps, but they serve the same purpose as a source of information of any geographical area. Cartography helps in the reduction of the large surface of Earth in digital or analogue form. The relationship between geographers and maps has ensured the growth of this sub-discipline.

The sub-discipline of cartography can be called an artistic, geographic, and technical science. The subject matter revolves around the features of the Earth's surface and heavenly bodies. A cartographer should know the pattern and distribution of spatial features to locate them with proper symbols and graphs. He should also know how to generalize data, as it is one of the most challenging tasks. Generalization can be defined as simplifying geographical data at a smaller or larger scale but remains readable. It requires prior knowledge on the part of a cartographer to be able to analyze and synthesize. It is, therefore, can be called a scientific science with scientific background and methods. A map is prepared for the communication of facts and phenomena. A good map successfully communicates the facts better and serves as a communication tool.

Communication integrates the harmonics of tools, rules, and framework to illustrate an idea by the author that the receiver can comprehend that particular idea. When considering communication, one is dealing with the communication device and is also concerned with the

sender, or author of the communication,' and the receiver, the person to whom the communication is directed. The most common tools of communication are:

1. Literacy – written language
2. Articulacy – spoken language
3. Numeracy – numbers
4. Graphicacy – graphic devices range from photographs, drawn pictures, graphs, and diagrams (Figures 1.2 and 1.3).

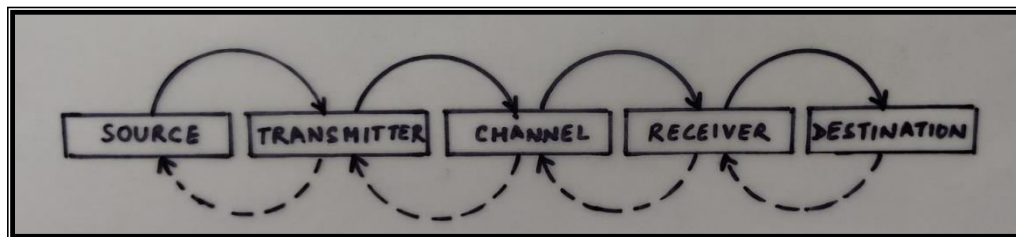

Fig. 1.2 Elements of a communication system

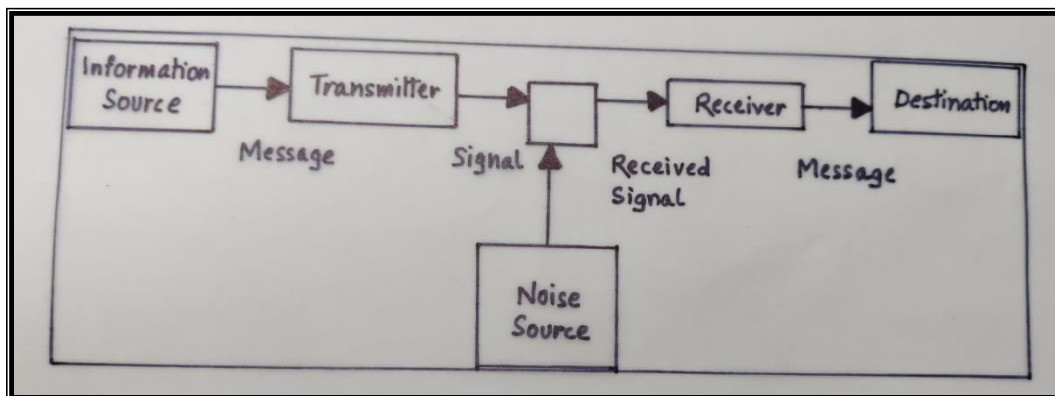

Fig. 1.3 A typical model of communication

The cartographic communication system is one such system that is composed of an information source, information channel, and receiver. Here, the cognition of the designer is to objectivity corresponds to an information source. The information of geographical knowledge is symbolized (corresponding to encoding) and drawn on a map. Therefore, a map is a carrier and the channel of information. The receiver deciphers the symbols from the map and forms the cognition to objectivity or reality. The cartographic information communication model (Figure 1.4) was first brought in by A. Kolacny (1969), a cartography scientist from former Czechoslovakia. He brought up the concepts of cartographic information and the communication

of cartographic information. The model depicts that this communication system comprises of four processes, namely,

- The acquisition of geographic environment information
- The formation of the geo-information carrier: map
- Comprehension on geographic environment information
- Formation of the mental map of geographical spatial information

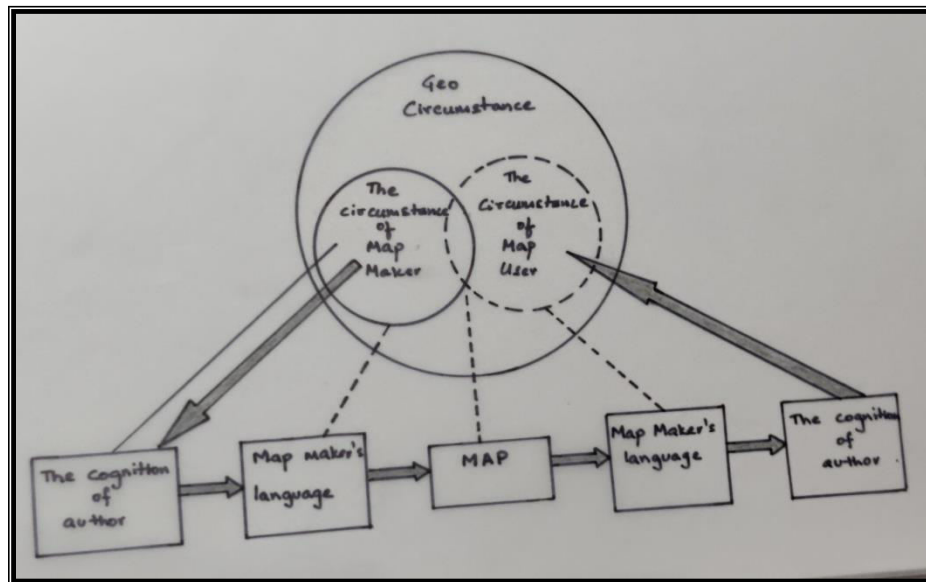

Fig. 1.4 The Cartographic Communication model of Kolacny (1969)

In other words, the cartographic communication system is a type of visual communication where maps are a form of visual communication- 'a special-purpose language for describing spatial relationships'. The relationships shown are among the map maker, environment, map, and the map user; this constitutes the functioning whole commonly referred to as the cartographic communication system where the map is the communication tool.

Cartography users range from manual mapmaker who makes simple maps to those who perform specialized cartographic techniques. The end-users of maps are often prepared by consumers, such as researchers, teachers, cartographers, etc. Nowadays, cartographers are engaged in commercial firms and agencies to compile, edit, design, and produce diversified maps, ranging from road maps to relief or plans for residential colonies.

The scope of cartography has expanded due to various uses of the Geographic Information System (GIS). The scope of cartography has diversified, as earlier; it was annotated as the art of mapmaking. Interest in cartography as a discipline has increased as users are now studying the origin of cartography, skill, maintaining map collections, making and teaching the usage of maps. Today, modern cartography helped us find solutions to different problems on Earth's surface like watershed management, weather forecasting, urban planning, forest management, and many more. The scope of cartography is related to the information about Earth's surface. The discipline of cartography can be traced back to the history of art or literature of prehistoric times. Maps have helped in recording and exploring the human's past.

1.3.3 BRANCHES OF CARTOGRAPHY

The field of cartography can be divided into the following three branches:

- Theoretical
- Analytical and
- Applied

Several other sub-branches with increasing specialization have also developed over time like:

- Thematic cartography,
- Scientific cartography,
- Aerial cartography,
- Statistical cartography
- Geographical cartography etc.

Theoretical Cartography includes the theoretical and conceptual aspects, which are focussed on the tasks of map design, content, map editing, and visual representation. It deals with the conceptual facets of the available maps and maps to be made as required by the user. A theoretical cartographer design maps according to the need and demand of map availability.

Analytical Cartography focuses on the quantitative and mathematical relationships inherent to cartography, making it a normative science. It brings forward new concepts like Mollering's (1977, 1991, and 1994) and Muller's (1991).

Applied Cartography deals with final mapmaking, that is, layout and the final drawings of the map. In the beginning, a theoretical cartographer tries to outline the guidelines or rules on which an applied cartographer bases his/ her application. An applied cartographer focuses on the used part of cartography and helps in better planning and executing the information given on maps.

1.3.4 DEVELOPMENT OF CARTOGRAPHY

The history of Cartography can be traced back to the history of humankind. The discipline of cartography has developed in four distinctive phases:

Ancient Period (up to 400 A.D.)

Medieval Period (400 to 1500 A.D.)

Early Modern Period (1500 to 1900 A.D.)

Recent period (1900 A.D. onwards)

The Ancient Period (up to 400 A.D.)

The ancient period can be divided into the following four sub-periods:

Primitive Cartography

Greek Cartography

Roman cartography

Asian cartography

Primitive Cartography: One of the oldest known maps was discovered in Babylon, which was made on baked clay showing mountains and rivers. The Babylonians were the first to map Earth's shape and size on a flat- circular disc. The early inhabitants used to draw on wood, skin, or bone they experienced in their day-to-day life. The earliest civilization of Egypt, Babylonia, and China established the form and extent of the boundaries. The land surveying task was carried on for taxation and land maintenance by the rulers or kings, recorded on maps.

Greek Cartography: The very much work of modern cartography is credited to Greeks and Arabs. They succeeded in measuring the circumference of the Earth. The first attempt to create a scale map was made by Anaximander, with Greece as its center. Eratosthenes attempted to calculate the circumference of the Earth which later on was improved by Hipparchus. He divided the circle into 360 degrees and identified latitudes, longitudes, and the Equator. In his *Guide to*

Geography, Ptolemy adopted the division of the circle into 360 degrees and rejected Eratosthenes's almost correct calculations, and preferred Posidonius's wrong estimates of the Earth's circumference. This miscalculation affected cartography's pace as a discipline (Figures 1.5, 1.6, and 1.7).

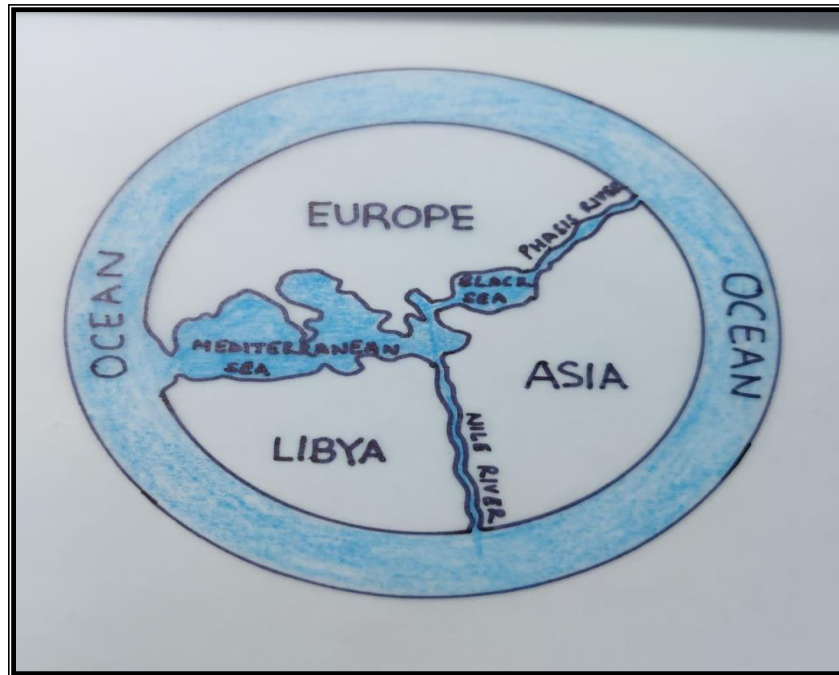

Fig. 1.5 Anaximander's World Map

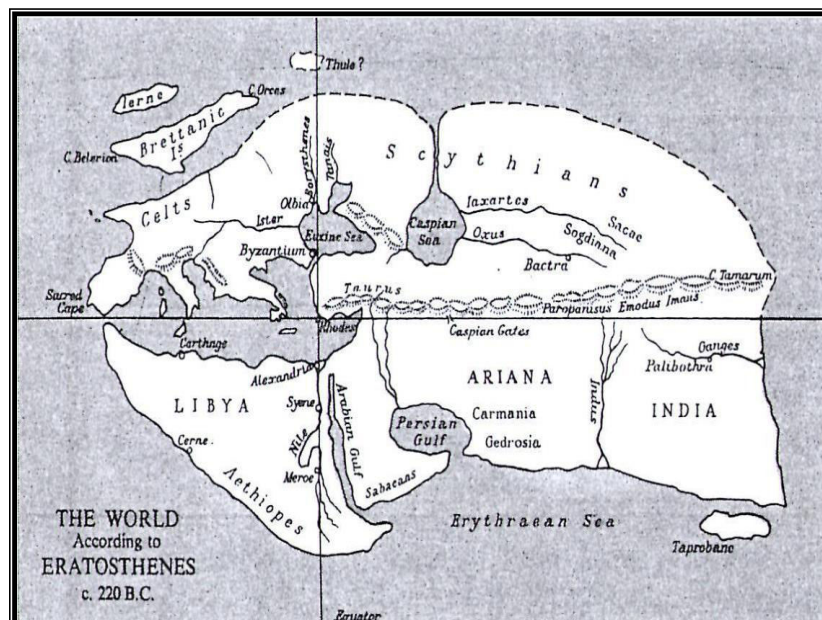

Fig. 1.6 World Map by Eratosthenes

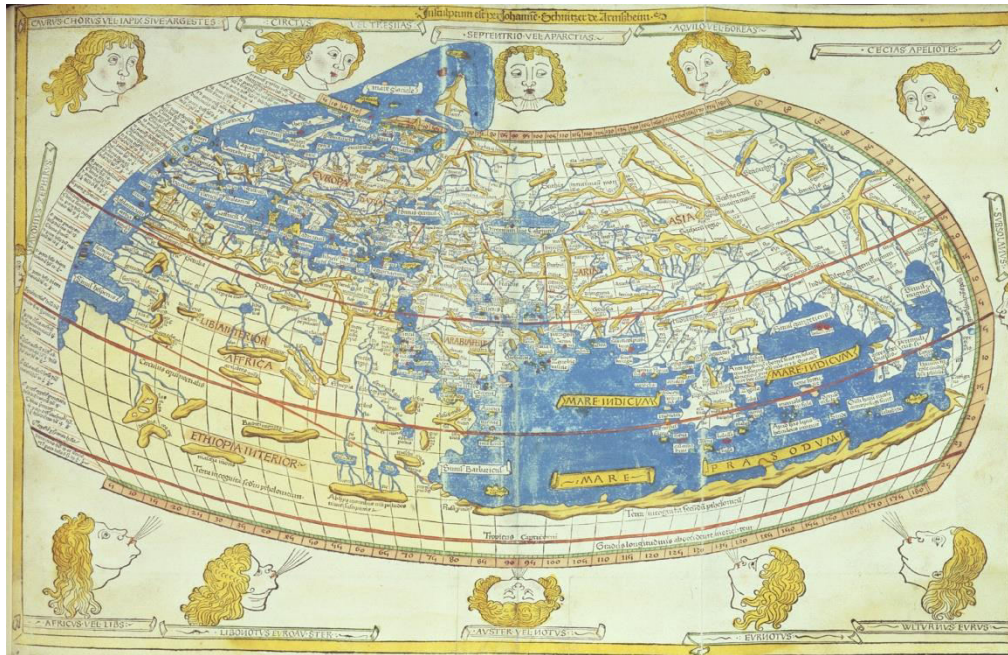

Fig. 1.7 Ptolemy's Map of the World

Roman Cartography: Roman Cartography mainly focused on the campaigns for the officials' armed forces and travels, and they were less interested in scientific cartography. They made maps of roads and battlefields. *Orbis Terrarum* was circular, which Marcus Vipsanius made in 12th B.C. Pliny in his 'Natural History' later confirmed it.

Asian Cartography: In ancient India, Aryabhata was the first to state that Earth's spherical shape and discovered the Earth's relative movement. Bhaskara calculates the Earth's circumference (39,967 km), its diameter, and surface area. China, Japan, and Korea were also involved in making maps.

Medieval Period (400 A.D. to 1500 A.D.)

The medieval period was when maps were copied without verifying them, which resulted in an increasing number of errors. During this period, T- maps or T-O maps (Figure 1.8) were made, representing Europe, Asia, and Africa, separated by 'T' formed by the Nile River and the Mediterranean Sea. Jerusalem was kept at the centre of the map, and Earth was shown as a flat disc. Ptolemy's *Geography* became most prominent in Europe; it exerted influence on promoting cartographic techniques and voyages. In 1489, Henricus Martellus attempted to make a world

map. By the end of 13th century, surveys were conducted, and many printed editions of books with maps flooded the market, which was more accurate than before.

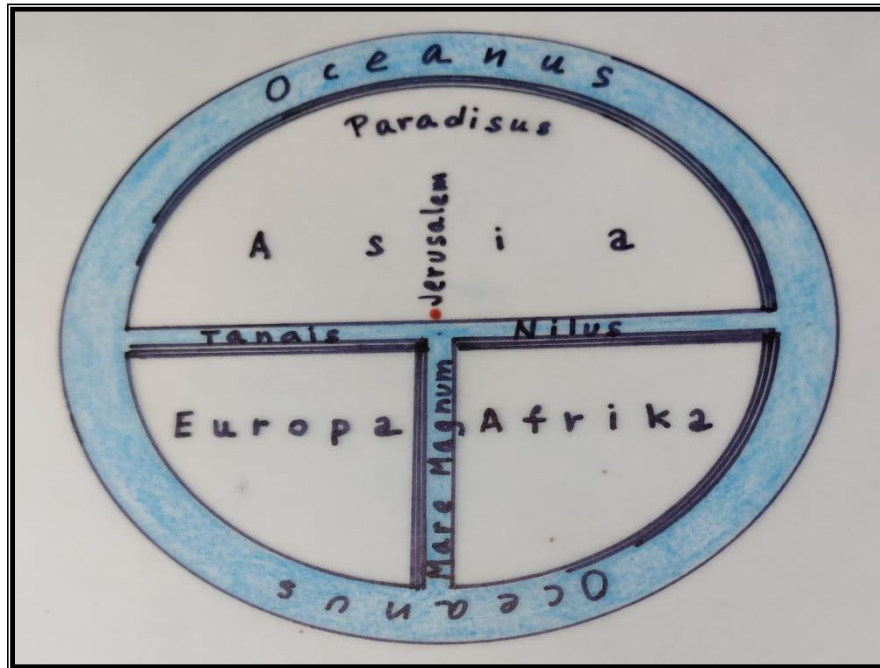

Fig. 1.8 Orbis Terrarum

Early Modern Period (1500 to 1900 A.D.)

Cartography as a discipline progressed in the fifteenth and sixteenth century, due to increasing voyages and exploration by Europeans searching for land. Europeans started to focus on cartographic techniques during the renaissance in Europe. In 1507, a German cartographer *Martin Waldseemular* prepared a North and South America map. America was shown as a separate continent that came to be known as *Carta- Marina* (Figure 1.9). *Gerhard Mercator* in 1538 made a world map and in 1596, Mercator' projection was developed by him (Figure 1.10). Edmund Halley was the first to illustrate wind directions, and he also prepared an isothermal map. Printed atlases and maps were in demand in the 16th century. There has been an effort to obtain true projections, direction, distance between places, and accurate area determination on a plane surface in early modern times.

In 1779, Rennell published the map of Hindustan in London. London developed as a center of cartography in the 18th century. One of the most prominent cartographers was

Arrowsmith; he prepared nine Pacific Ocean sheets in 1778. The reliability and accuracy of maps improved due to the systematic representation of Earth's features on a flat surface. In the 17th and 18th centuries, printed maps were produced with more excellent reliability and precision.

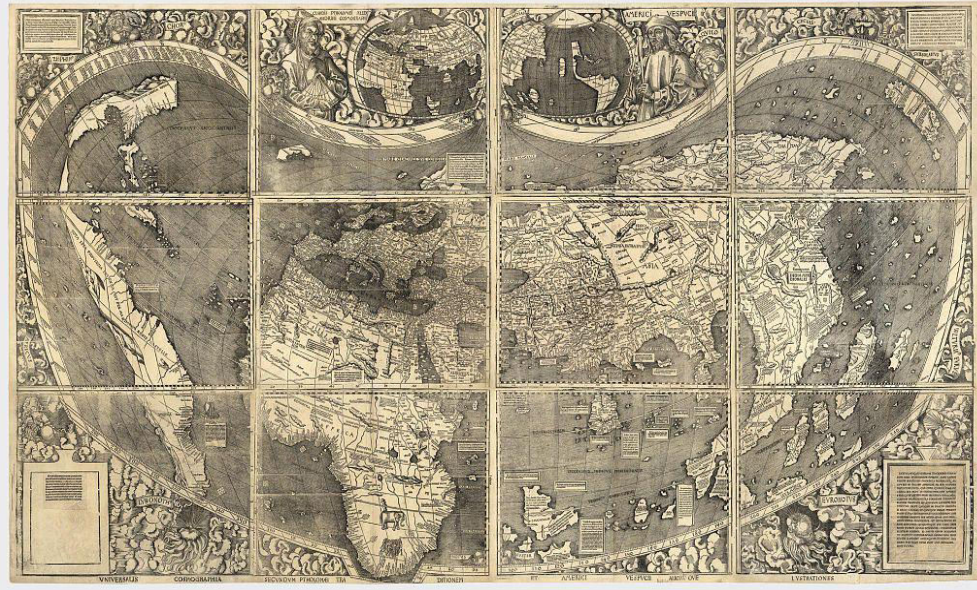

Fig. 1.9 Martin Waldseemular's World Map showing *Carta Marina*

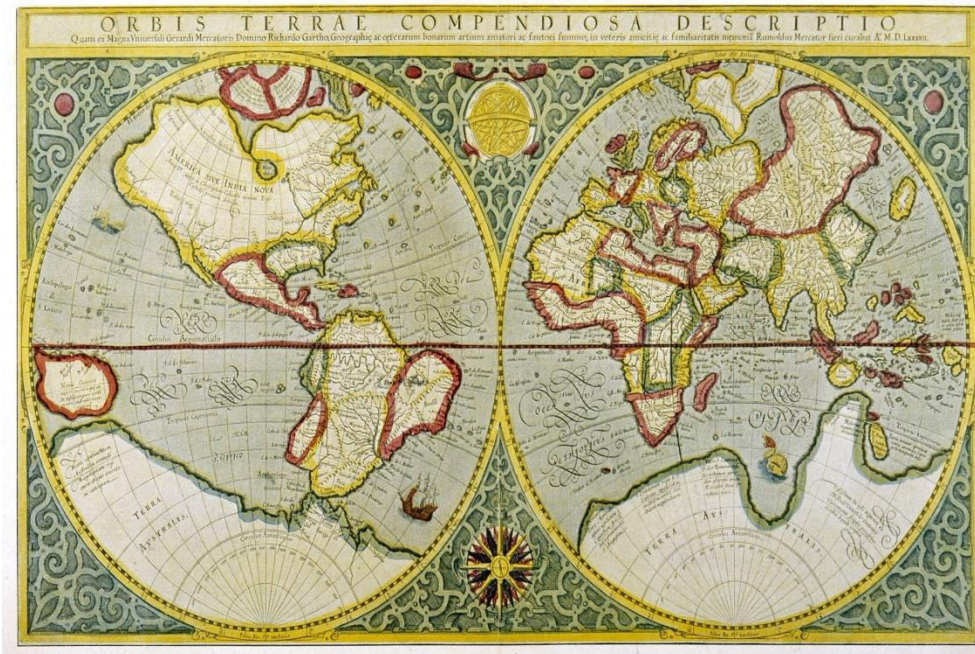

Fig. 1.10 Mercator's Map of the World

Recent period (1900 A.D. onwards)

In the 19th century, there have been national survey institutions in many countries with advanced surveying techniques and observatories. Aerial photography allowed mapping even challenging terrains on the Earth. Aircraft along with installed cameras were used for surveying. Technological advancement has revolutionized the field of cartography. Many organizations like Survey of India, U.S. Geological Survey, and Ordnance Survey of Great Britain prepared larger scale maps with minimal errors or distortions; they even produced variety of maps for different purposes.

Modern cartography has reduced the cost of map production and increased the speed of production, accuracy, and maps' output. The process of cartography accelerated due to the availability of better cameras and tools. Thematic maps were constructed to meet particular needs. John Bartholomew published many national atlases (Figure 1.11). Thus, there has been an increase in the number of map users and professional cartographers recently.

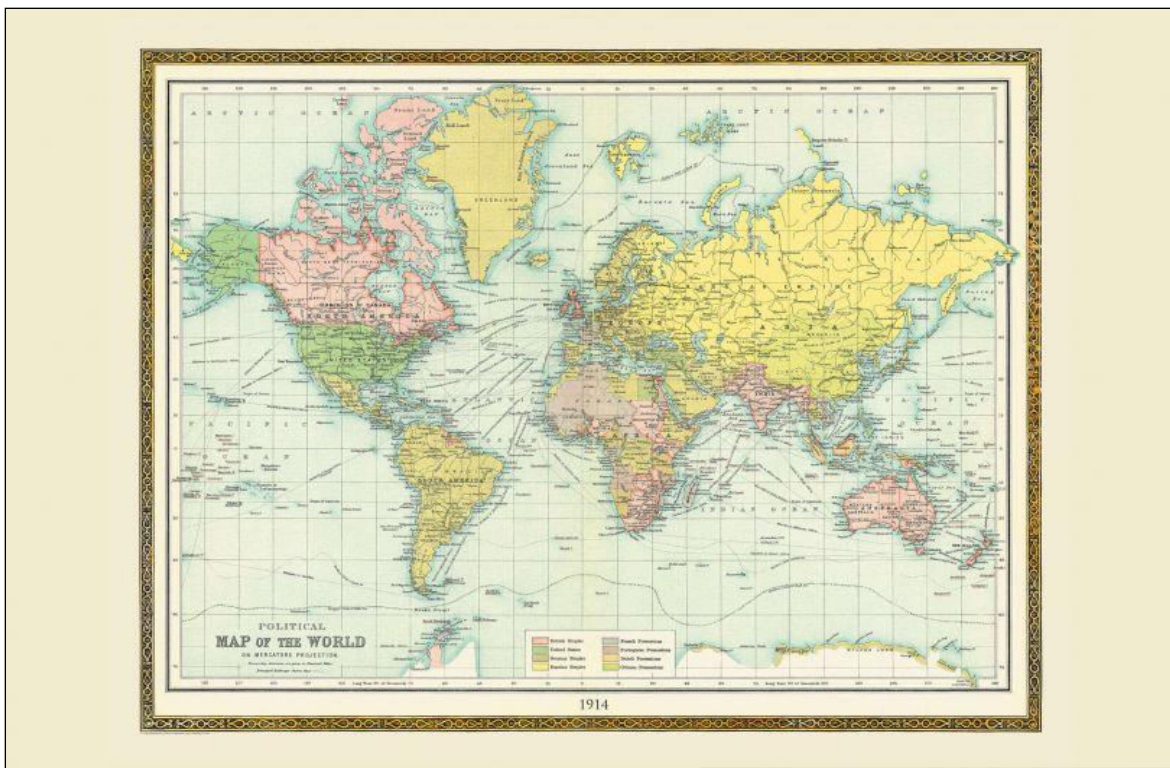

Fig. 1.11 Bartholomew's Political World Map (1914)

1.4 MAPS

The word '**map**' has been derived from the Latin word '*Mappa*,' meaning paper. A graphical representation of the Earth's surface can be defined as a **map**. It is impossible to show every Earth's features in great detail; therefore, a map is constructed as per the need of the consumer. Maps not only show the physical aspect but also represent the cultural and social features. Maps can be represented on a plane surface at a reduced scale. As you know, the art of map making preceded reading and writing, as earlier men used to make a pictorial representation of familiar places. A good cartographer has the expertise of choosing the right kind of colours, symbols, and lines.

Earlier, two-dimensional maps were made, but today, three-dimensional maps are also into use with the modern graphic system's help. Maps are prepared on a scale based on the actual size of the objects on the map. A map does not represent reality, as it can be referred to as the symbolic representation of any place. It shows the biases and agendas of the cartographer. It shows physical aspects, political boundaries, roads, rivers, climate, population, etc.

A cartographer tries to project only those details they want to represent using symbols or graphs, whereas a photograph will show all the photographed area features. A photographer cannot omit the physical features present on the ground as per their need, but a cartographer can. A map can show intangible objects such as the political boundary of any country, region, or state which are not physically present. All the cartographic products such as charts, sketches, and plans are maps. A **plan** tries to represent a detailed part of any area like towns and cities.

1.4.1 TYPES OF MAPS

Each map is unique in its design, content as well as construction. Based on specific features, they can be classified into several types that have been discussed in this section:

Based on Scale: Maps based on the criterion of scale can be classified as:

1. Small Scale Maps
2. Large Scale Maps

Small Scale Maps -These are drawn to show sizeable geographical areas with few details on them. They are drawn on a scale of 1: 1,000,000. These are divided into:

a. Wall Maps: These maps are drawn on a small scale to show the country, region, or continent. They are generally larger than atlas maps. The essential purpose of this map is to use it in classrooms or lecture halls to teach students.

b. Atlas Maps: These are small-scale maps representing a large area of continent or country showing physical or cultural features. These are in the form of a book meant for personal use. Specific purpose atlases such as a watershed atlas, agriculture atlas, Census atlas, etc., are also prepared.

Large Scale Maps - Present small areas at a large scale. Any geographical unit or area is shown in greater detail, such as a village, town, city, etc. They are drawn at a scale of 1:1,000, 1: 2,000, or 1:500. These can be divided as follows:

a. Cadastral Maps: The term '*Cadastral*' is derived from the word '*cadastre*,' meaning a list of register or public records of land property. The government maintains these for taxation and ownership of land. Cadastral maps are more detailed and are maintained to show the boundaries of agricultural field, city boundary, plan of house, etc. They are drawn at a scale of 1: 4,000 or 1:2,000 and larger.

b. Topographical Maps: Topographical maps are large-scale maps that show physical features of the Earth such as relief, forest, agricultural land, etc., along with cultural aspects. It uses uniform colour and symbol to represent the topography of any relief, using contour lines. The closely spaced contour lines show steeper terrain, whereas contour with regular intervals shows changes in the elevation. It is used for military purposes, surveying, hunting, etc. These are drawn at a scale of 1:50,000 and 1: 25,000.

Based on function

Maps based on function can be classified as follows:

Physical Maps: These maps are prepared to show the natural features such as relief, soil, geology, vegetation, drainage, etc. These can be further classified as:

a. Relief Maps: It shows various relief features such as mountains, plains, plateaus, coasts, etc.

- b. Geological Maps:** Geological maps are prepared to show the geology or the structure and types of rocks.
- c. Climatic Maps:** These maps show climatic conditions of an area such as wind, temperature, rainfall, pressure, etc. It uses different colours to indicate a different climatic pattern.
- d. Soil Maps:** These maps represent different types of soil and its pattern. It is generally used in the field of agriculture.

Cultural Maps: These are prepared to show the cultural aspect of any geographical unit. These are classified as follows:

- a. Political Maps:** Political maps are prepared to show any country's political boundaries, state, or continent. It is used for planning and administrative purposes.
- b. Historical Maps:** These are prepared to show the various historical features.
- c. Social Maps:** These maps show the socio-linguistic feature such as language, religion, race, etc., of any geographical area.
- d. Strategic Maps:** Strategic maps are prepared for strategic purposes as they are more detailed than other types of maps.
- e. Economic Maps:** An economic map represents any economic activity or natural resources of any area such as trade routes, location of crops, industries, market, and minerals.
- f. Population Maps:** Population maps are prepared with planning and development as it shows the density, growth, distribution, occupation structure of any given population.

Based on relief representation

These are classified as follows:

Hypsometric maps: These are those maps that represent the relief and terrain. Topographical maps prepared by Survey of India are the example of hypsometric maps.

Planimetric maps: These maps are prepared to show the horizontal position on the Earth's

Based on information

General-purpose map: The general purpose maps are those which depict large area at a small scale, such as an atlas, topo-sheets, and wall maps.

Thematic map: Thematic maps are theme-based and show particular purposes such as demographic data or rainfall distribution. Location, boundaries, coastlines form the base of the

thematic maps, and the different layers of non- topographic elements are layered onto the base using **GIS** (Geographic Information System) and other techniques.

Special-purpose map: These maps are prepared to serve a particular purpose on a specific topic, such as DEM (Digital Elevation Model), which shows elevation is an example of a special-purpose map.

1.4. 2 FUNCTION OF MAPS

The map's function has changed over the decades, as initially maps were made on paper, wood, or clay, but recently computerized maps have popularized. There has been a change in the map function, as paper maps serve the purpose of the map display and information storage. For navigation, maps can be used to display the correct route or location. Digital maps have made navigation easier as map users can customize the map as per their needs.

Maps serve the essential function of measuring distance, area, and direction. A map consists of various features, i.e., roads, rivers, canals, and railways. These features are either in a straight line or in a zigzag pattern. The straight lines on maps can be easily measured with the scale of divider, whereas the zigzag lines can be measured with the help of thread or an instrument called a **Rotameter** (Figure 1.12).

A map has four cardinal points or directions known as East, East, North, and South. These directions are the basis for determining the features on the Earth's surface. The focus is vital for mapmaking. The direction is an imaginary straight line pointing towards the north. Any geographical area or unit can be measured to be shown on the map by using a polar **Planimeter**



Fig. 1.12 A Rotameter

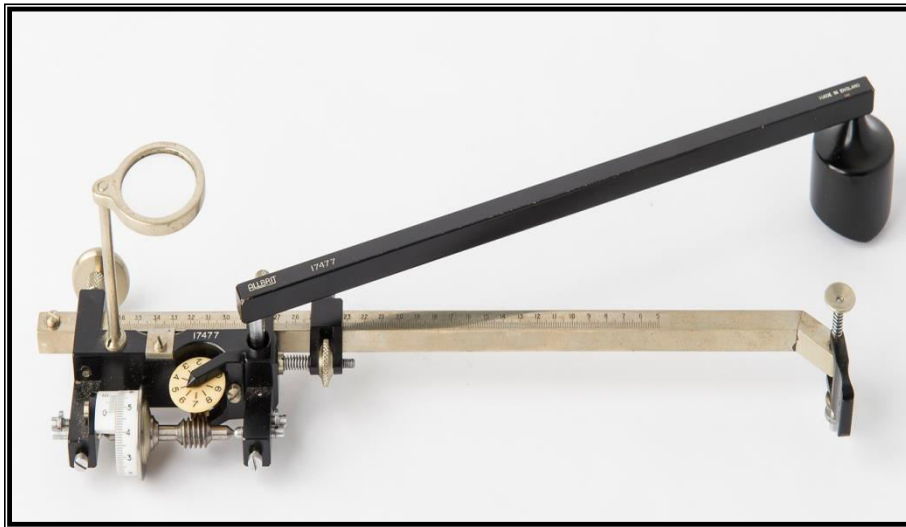

Fig. 1.13 The Planimeter

1.4.3 MAP AS A TOOL OF ANALYSIS AND SYNTHESIS

Representation of three-dimensional space. Maps have taken an essential part of our day-to-day life. We are often dependent on maps as they have proved to be a necessary tool for the analysis and synthesis of geographical data. It is used for planning resources, urban planning, resource management, etc. They are used as an analysis tool to make and test hypotheses. For example, analysis of the distribution of rainfall can be done with the help of maps. Maps have proved their worth from time to time, and the following are the areas of analysis and synthesis:

- 1. Planning:** In planning, maps are an important tool of analysis as they used for developmental process at various levels. Maps are the best way to plan any resources at the regional, national or international level.
- 2. Research:** Map as a tool of analysis is used in the research process at several levels to solve society's problems. The use of statistical and quantitative techniques in the processing of data to be represented on maps has further increased maps' utility as research tools.
- 3. Locating Places:** Maps serve the purpose of locating places on Earth. These are used for acquiring knowledge of any site or surrounding area.
- 4. Military:** During the modern period, maps were extensively used and produced for war and conflict between nations. It was used as a tool to incorporate any operation or battle to be carried out in an area that has not been visited before.

The map usually presents an objective and irrefutable appearance of factual and topographical or geographical information. It is an elaborate expression of power relations embedded within the social and political space constructed through the territory and place names' discourse. For instance, they usually do not provide society with its hierarchical organization but subtly make it visible through the field boundaries, administrative or religious units, or national borders.

Harley (1992) deconstructs the map by challenging its assumed autonomy as a mode of representation. It is about the map's definition as 'a symbolized image of geographical reality representing selected features or characteristics' by the International Cartographic Association (ICA). Thus by positioning maps within the societal power relations, Harley provides a richer purpose of more contemporary maps.

1.5 SUMMARY

In this unit, you have studied that maps are drawn at a reduced scale, and the mapping processes involve the visual communication of spatial information. Cartography can be attributed as an art, science, and technology of mapmaking. The process, practice, skill, and study of making a map are known as cartography. The subject matter revolves around the features of the Earth's surface and heavenly bodies. The task involves manual mapmaking who makes simple maps, to those who perform specialized cartographic techniques. The end-users of maps are often prepared by consumers, such as researchers, teachers, cartographers, etc. Digitization of

maps has brought a revolution in the cartographic discipline. It helps in the faster generation of maps with no loss of quality of the maps. The scope of cartography has expanded due to various uses of the Geographic Information System (GIS). The scope of cartography has diversified, as earlier; it was annotated as the art of mapmaking. The field of cartography can be divided into theoretical cartography and applied cartography.

During ancient times, cartography was prepared on baked clay and wood; then, it shifted to paper credited to Greeks and Arabs. They measured Earth's circumference, latitude, and longitude. During medieval times, T- maps were made representing Europe, Asia, and Africa. Printed maps flooded the market during this time. In the 15th century, voyages and exploration were carried on by Europeans in search of land. Mercator projection was developed, precise location, and areas were determined during the early modern period. In recent times, the cost of map production has reduced, and the output of maps increased.

It is challenging to portray minute details of the Earth's surface on paper; there, a map is prepared as per the user's demand at a reduced scale. Maps can be divided based on scale, function, relief representation, and information. A cartographer represents features that are of utmost importance. Maps serve the purpose of displaying facts and storing data. Maps are an integral part of our lives as they are an important tool for analyzing and synthesizing geographic data. It is used for planning, research, locating places, etc.

1.6 GLOSSARY

Cartography: Cartography can be defined as an art, science, and technology of mapmaking.

Cardinal Direction: East (E), West (W), North (N), and South (S)

Cadastral Map: A cadastral map is a large-scale map that maintains a record of land property and boundaries at a scale of 1: 4,000.

Map: A graphical representation of the Earth's surface is called the map.

GIS: Geographic Information System integrates hardware, software, and data for capturing, managing, analyzing and displaying spatial information.

Plan: A plan is a detailed map showing small areas like towns, cities, and villages.

1.7 ANSWER TO CHECK YOUR PROGRESS

1. Answer the following questions briefly.
 - a. Why is there a need for maps?
 - b. Explain the function of a map.
 - c. In how many phases the discipline of cartography has been divided?
 - d. What is the generalization of a map?
2. Differentiate between a small scale map and a large scale map.
3. List out the different types of maps.
4. Explain the scope of cartography.
5. A map is a tool of analysis and synthesis. Elaborate.
6. Explain the types of maps based on information.

7. Fill in the blanks:

- a. The visual communication of spatial information on a piece of paper is known as _____.
- b. A good cartographer is one who has the expertise of choosing right kind of _____, _____, and _____.
- c. The process of cartography involves _____, _____, _____, and _____ of maps.
- d. Cartography can be termed as the _____, _____, and _____ of map-making.

8. Fill in the blanks

- a. A graphical representation of the earth's surface can be defined as _____.
- b. The art of map making is known as _____.
- c. A person who makes map is known as _____.
- d. Any geographical area or unit can be measured to be shown on map is termed as _____.
- e. Map which is drawn at a scale of 1: 4,000 is called _____.

HINTS ANSWER TO CHECK YOUR PROGRESS

1. (a) Maps are required for navigation, demarcating boundaries, prediction of disaster, etc.
 - (b) Maps serve the essential function of measuring distance, area, and direction.
 - (c) The discipline of cartography has developed in four distinctive phases: (i) Ancient Period
(ii) Medieval period (iii) Early Modern Period and (iv) Recent Period

(d) Generalization can be defined as simplifying geographical data at a smaller or larger scale but remains readable.

2. **Small scale maps** are those which are drawn to show sizeable geographical area with few details on them. They are drawn on a scale of 1: 1,000,000. **Large Scale Maps** represent small areas at a large scale. Any geographical unit or an area is shown in greater detail, such as a village, town, cities, etc. They are drawn at a scale of 1:1,000, 1: 2,000, or 1:500.

3. Wall Maps, Atlas Map, Cadastral Map, Topographical Map, Relief Map, Climatic Map, Geological Maps, Political Maps, historical Maps, Social Maps, Strategic Maps, etc.

4. The scope of cartography has expanded due to various uses of the Geographic Information System (GIS). It is related to the information about Earth's surface

5. Maps have taken an essential part of our day-to-day life. We are often dependent on maps as they have proved to be a necessary tool for the analysis and synthesis of geographical data. It is used for planning resources, urban planning, resource management, etc. They are used as an analysis tool to make and test hypotheses. For example, analysis of the distribution of rainfall can be done with the help of maps.

6. Based on the information, maps can be divided into General Purpose Map, thematic map. Special Purpose Map.

7. (a) Mapping (b) Colours, Symbols and Lines (c) Collecting, processing, drawing, and marketing (d) Science, art, and technique

8. (a) Map (b) Cartography (c) Cartographer (d) Planimeter (e) Cadastral Map

1.8 REFERENCES

1. Britannica, T, (2017), Editors of Encyclopaedia. Cartography, Encyclopaedia Britannica. <https://www.britannica.com/science/cartography>

2. Harley, J. B (1968) "The Evaluation of Early Maps: Towards a Methodology," *Imago Mundi*, Vol. 22, pp. 62-74.

3. Krygier, J. (1995), "Cartography as an art and a science?", *The Cartographic Journal*, Vol. 32. Pp. 3-10.

4. Misra, R. P, and A. Ramesh., (revised, 1989), *Fundamentals of Cartography*, Concept Publishing Company, Delhi.

5. *Practical Work in Geography*. NCERT textbook for Class XI.

6. Robinson, A.H., and Selep, R.D., (1969), Elements of Cartography, Wiley, New York.
7. Ulugtekin, N. & Dogru, A. (2007). Current Scopes of Cartography: Small Display Map Design.
8. https://www.researchgate.net/publication/307205584_Cartography

1.9 TERMINAL QUESTIONS

1. Name the different types of cartography during the ancient period.
2. Explain the different branches of cartography.
3. Define cartography according to International Cartographic Association.
4. List any two types of small scale map?
5. What are the different types of physical maps?
6. What is a rota meter?
7. List out four major cardinal points?
8. Define direction.

ANSWER

1. (i) Primitive Cartography (ii) Greek Cartography (iii) Roman Cartography (iv) Asian Cartography
2. Applied Cartography and Theoretical Cartography
3. Cartography is the discipline dealing with the conception, production, dissemination, and study of maps. Cartography is also about representation- the map. This means that cartography is the whole process of mapping.
4. Wall Map and Atlas Map
5. Relief Map, Geological Map, Climatic Map, and Soil Map
6. The straight lines on maps can be easily measured with the scale of divider, whereas the zigzag lines can be measured with the help of thread or an instrument called a Rotameter.
7. North (N), South (S), East (E), and West (W).
8. Direction is an imaginary straight line pointing towards the north.

UNIT 2- RELIEF MAP AND DIAGRAM: DEPICTION OF RELIEF, SLOP, AND GRADIENT, PROFILE, METHODS OF SLOP ANALYSIS (E.G. WENTWORTH, SMITH) AND ALTIMETRY FREQUENCY CURVE

2.1 OBJECTIVES

2.2 INTRODUCTION

2.3 MEANING OF RELIEF

2.3.1 METHODS OF SHOWING RELIEF

2.3.2 HISTORY OF RELIEF REPRESENTATION

2.3.3 SLOPES AND GRADIENTS

2.3.4 WENTWORTH'S METHODS

2.3.5 SMITH'S METHODS

2.3.6 PROFILE

2.4 SUMMARY

2.5 GLOSSARY

2.6 ANSWER TO CHECK YOUR PROGRESS

2.7 REFERENCES

2.8. TERMINAL QUESTIONS

2.1 OBJECTIVES

After having the detailed study of this unit you will be able to

- Understand several approaches for representing relief features.
- Recognize typical landform patterns in specified locations by understanding the development of qualitative approaches for landforms and landscapes on the earth's surface.
- Using these approaches, you may determine the slope and gradient of the area in question.
- Understand how mathematical or quantitative methods are developed depending on mathematical inputs.
- Learn about recent advancements in the methods of evaluating relief aspects. Techniques are employed in the GIS environment to create three-dimensional aspects of the earth's surface.

2.2 INTRODUCTION

Identifying and mapping the many relief features of the earth's surface has long been a challenge for geographers, particularly cartographers. Every method has advantages and disadvantages, and there is always room for innovation. There may be several reasons for the requirement to map the various features. A substantial component of geographical studies is the systematic observation of the earth's surface, the interpretation of relief features of different regions of the earth's surface, their implementation in various field areas, and their depiction appropriately.

You will learn about relief in this unit, which has been extensively examined, analysed, and interpreted by generations of geographers. The word incorporates height, the third dimension of geographical space, which is one of the most noticeable abnormalities of the earth's surface. The current relief of any section of the earth's surface is the outcome of dynamic processes that are occurring in that area. It is also important to understand that, while the term relief is much older, the development of geomorphology in the nineteenth century led to not only the description and analysis of landforms, but also to the more accurate and effective representation of landforms of varying size, shape, and height. As a result, distinct ways for depicting relief

characteristics or topography of various areas of the earth's surface emerged more quickly in different parts of the world.

The term topography originated in ancient Greece and was used as a thorough description of a location in ancient Rome. The term is derived from the Greek terms *topos* (meaning "place") and *graphia* (meaning "writing"). In classical literature, this refers to writing about a certain location or locations. Topography is still used in its original definition in the United Kingdom and throughout Europe. This lesson is more concerned with describing relief as well as the methods used to depict relief in geographical studies. It is vital for you to comprehend all of the various ways to understand the relief characteristics as they are now, as well as how they were in the past and how they may evolve in the future. If we look back at previous studies, we may see a common interest in relief or topographic mapping, as well as mapping begun for defiance purposes. The first comprehensive maps in the United States were created by the "Topographical Bureau of the Army?" during the War of 1812, which eventually became the Corps of Topographical Engineers in 1938. After the United States Geological Survey took over national mapping in 1978, the term topographical persisted as a general term for extensive surveys and mapping programmes, and was accepted as standard by most other nations. De la No, a geographer and a lieutenant colonel in France, published his work on "forms of terrain" and so helped to the creation of mapping for military purposes. Ordnance Surveys were the name given to detailed military surveys in the United Kingdom commencing in the late eighteenth century; this phrase was used as a generic name for topographic surveys and maps far into the twentieth century. In the twentieth century, the term topography began to be used to represent surface description in other domains as well. With the arrival of the twenty-first century computer cartography, GIS, drastic changes occurred, and more and more effort is being done to increase accuracy in this sector all over the world. You may have realized by now that examining the various relief features is an important component of comprehending geography. In this context, you should be aware that a high plateau may have a high altitude but a low relief, whereas mountains in coastal areas may have a low altitude but a high relief. In other words, knowing relief features is critical in geographical research. The horizontal and vertical dimensions of the earth's surface, known as topography, have an effect on various elements of human life. As a result, geographers have been particularly interested in it. Understanding an area's terrain allows one to understand the borders of drainage basins, water and sediment flow channels.

Understanding alleviation also aids in agricultural soil conservation. Contour farming contributes to more sustainable farming on steep slopes. The relief of that particular place influences weather variations and the establishment of climatic regions to a large extent. Because of changes in elevation or a rain shadow effect, two geographically close sites may have drastically different precipitation quantities or timing. Precision knowledge of elevation differences is necessary in flying. The range and performance of radars and terrestrial radio navigation systems will also be affected by terrain. Not only that, but a mountainous or hilly environment might have an impact on the construction of a new aerodrome and the orientation of its runways. Detailed terrain studies can provide information on surface water flow and water body distribution across a specific area. Some of these examples may help you grasp the importance of knowing and mapping relief characteristics when studying geography. Topographic maps are commonly used to depict relief in most geographical disciplines. It has the potential to disrupt hydrological and climate systems over a wide area. In this manner, we may comprehend the relevance of relief features and various methods for mapping them from the beginning of map making to the present.

Physical landscapes were originally portrayed by mountain hill illustrations. Oblique and panoramic views were marked using the 15th to 18th century approach. Geomorphic painting evolved alongside landscape painting at the same period. Topographic representations were constructed from the oblique to straight method for the first time in Europe in the 18th century by topographers. In 1799, (Lehman) invented the flow line sign. This became known as the Hasheure line later on. The oscillations of massed slopes and planes are exhibited by connecting numerous Harpoor lines. It worked well on large scale maps.

The contour line and other linear designs were devised in the first half of the 18th century, but until 1730, when a native named Croquis used it to show the foothills of the Marwed River, it was only conceivable in the 19th century. Its usage on small scale maps began in 1840, followed by the use of lithic printing in the first half of the century, and geomorphic display in the latter (1870). Topographic displays such as contour line, issuer, shadow method, and so on, began to be utilized extensively. After the changes, the new maps are quite amazing. On a wide scale, features of land shape such as pulse, height, and slope are displayed; however contour lines and Hachures only disclose higher and steeper slopes on a small scale.

2.3 MEANING OF RELIEF

You are all aware that the elevation of the earth's features varies. The definition of relief is complicated since it involves various criteria. It is, indeed, an expression of height, slope, and form, while also representing the interactions that exist between these many elements. A Chinese saying perfectly describes this: if there were no mountain, the plains would not be visible. Indeed, identifying relief simply with high altitude zones is reductive; while slope, shape, and height are most apparent in mountainous regions, areas of the earth's surface that are relatively flat also exhibit diverse relief traits. As a result, you must have realized that relief exists over the entire terrestrial surface. Relief is defined as the difference between the elevations of the highest and lowest sites above mean sea level. Relief in geography refers to an area's highest and lowest elevation locations. Identifying diverse relief features and portraying them on maps is equally important for individuals studying geography and wanting to comprehend relief. We can state:

1. Mountains and ridges are the highest places on Earth's surface.
2. The lowest places include valleys and other low-lying areas.

To grasp an area's topography, one must first understand relief. Local relief is the quantitative measurement of a landscape's vertical elevation change. It usually refers to a small area. Because few regions have consistent height, a relief map depicts the increase and decrease in elevation. These divide landscapes into scales ranging from massive ocean basins and continents to tiny hills, spurs, cliffs, valleys, gorges, and river terraces.

Geographers have classified landforms into three classes of relief in order to analyze distinct earth features in a methodical manner.

1. Massive continental platforms and ocean basins are examples of first order landforms.
2. Continental masses, mountain masses, plateaus, plains, and lowlands comprise the second order of relief.
3. Individual peaks, cliffs, valleys, hills, spurs, gorges, caves, moraines, cirques, ripples, beaches, and other features are included in the third order of relief.

The various types of relief are apparent as fractures, faults, earthquakes, volcanoes, river erosion, glacier erosion, wind erosion, and so on. The aggregate of these processes allows one to

comprehend what should be assigned to whatever type of geodynamic, what relates to primitive forms, and what related to derived forms. Current reconstructions of paleo-climates, quantification of various processes, and understanding of time scales in the elaboration of shapes and formations all provide insight into the history and origins of features that we can see today. The numerous facets of relief studies have encouraged academics, particularly geographers, to make a number of classifications.

2.3.1 METHODS OF SHOWING RELIEF

The representation of relief characteristics on plain paper has always been a difficult because there is still room for improvement. Initially, topographic survey information was relied on surveyors' notes. Boundary delineation was derived from local cadastral mapping. Other local sources were also examined to determine the area's naming and details. However, inaccuracies and discrepancies were corrected for map making in the later rounds of surveying. As the art of map production evolved over time, so did various methods of depicting relief features on maps. The representation of the earth's surface on maps has limits because-

1. Earth features that exhibit relief are three-dimensional.
2. We primarily indicate the location of features in two-dimensional space, as you can see when you read maps.
3. The three-dimensional quality of the earth's surface may now be visualized to a large extent using current computer cartography.

You must recognize that the most accurate approach to depict varied relief characteristics on maps has yet to be discovered. The greatest problem for modern mapmakers is to create maps that not only depict the relief features but also accurately depict them statistically. The scale of a map greatly influences how relief elements are depicted.

Maps are classified according to scale:

1. Large size maps
2. Maps on a small scale.

You must understand the fundamental differences between these two types of maps. We can state:

(i) Large-scale maps depict smaller areas with precise relief features. Large-scale maps depict the nature and attributes of relief features more precisely than smaller-scale maps.

(ii) Small-scale maps cover larger areas and provide less information. All relief features are generalized on small-scale maps.

How we depict a specific relief element is mostly determined by our goal. Why is it vital to present that specific relief feature in a specific location at a specific time? These are evident concerns that arise when a person employs a specific way for representing relief elements. The evolution of various methods and techniques indicates a long-term process that is the result of the efforts of countless people who are attempting to improve methods of representing relief features along their long journey from hachure lines to digital elevation models and topological modelling. So far, various methodologies in various or combination forms have been utilized to illustrate relief characteristics on the earth's surface. Hachuring was supplanted in the early 18th century by a scientific kind of hill darkening. Hill shading is similar to the light and shadow effect. Valleys and the sides of mountains appear to be cast in shadow. This is a visually appealing way for offering an overall view of an area's relief the shade of a hill. However, it does not display height, implying that it is no more accurate than hachuring. Spot heights are used to show the exact elevation of the terrain at a certain spot. Spot heights are represented by a dot (or triangle) and a number that represents the altitude (height above sea level) at that spot. While spot heights provide elevation precision, they do not supply much information about the land's shape. As a result, they're frequently utilized in conjunction with hill shading, layer tinting, and contour lines. Which strategy should be employed depending on the time availability and study area? You can gain a better understanding of the evolution of approaches and strategies for representing relief characteristics as follows:

2.3.2 HISTORY OF RELIEF REPRESENTATION

Physical landscapes were originally portrayed by mountain hill illustrations. Oblique and panoramic views were marked using the 15th to 18th century approach. Geomorphic painting evolved alongside landscape painting at the same period. Topographic representations were constructed from the oblique to straight method for the first time in Europe in the 18th century by topographers. In 1799, (Lehman) invented the flow line sign. This became known as the

Hasheure line later on. The oscillations of massed slopes and planes are revealed by connecting numerous Hasheure lines. It worked well on large scale maps.

The contour line and other linear designs were devised in the first half of the 18th century, but it was only possible in the 19th century before its birth, in 1730, when a native named Croquis used it to illustrate the slopes of the Marwand River. Its usage on small scale maps began in 1840, followed by the use of lithic printing in the first half of the century, and geomorphic display in the latter (1870). Topographic displays such as contour lines, issuers, shadow methods, and soon began to be widely used. After the changes, the new maps are quite amazing. On a large scale, aspects of land shape such as pulse, height, and slope are depicted, but on a small scale, contour lines and Hasheure disclose only higher and steeper slopes.

The portrayal of the surface on a small scale is difficult, but numerous geodesy approaches have come into favours through replication techniques and drawings, and their popularity is growing. Geomorphic depiction of the earth's surface in visual form is a strong medium. Knowledge of the night, practice and talent in handicraft, and the ability to express it in three dimensions are also required. The reference view, colour, shading, and line tracing can all be customized. Some complicated and intellectual systems of topographical presentation have been improved and analyzed under morphological systems and included in the display of geography and landforms for specialized objectives. The landform unit area performance using this technique is currently average pulse analysis. Techniques for relative relief are also discussed.

1. Pictorial Representation

These are the basic methods for representing relief that have been employed from the beginning of the art of map making. Relief features were demonstrated using basic curves and illustrations. In 1503, a French thinker named Leonardo da Vinci began an effort by painting little hill-shaped features. Gygers, a Swiss resident for nearly a century, made an effective attempt by sketching lines resembling hachures with shading. Slowly, efforts to develop such systems began across Europe. As you would imagine, observable impacts are dominating in such processes. Some of these techniques include hachures, hill shading, layer shading, and tinting.

Hachures Method

A large-scale contour map with vertical illumination Major J.G. Lehmann was the first to use hachures to portray the landscape scientifically in 1799. He employed lines that were aligned in the aspect direction, with line thickness proportionate to slope. The generated maps were particularly beneficial for the creation of large-scale topographic military maps (Robinson et al., 1995). Slope hachuring refers to increasing the hachure thickness with slope and is analogous to analytical hill shading with vertical lighting. Imhof (1982) established five guidelines for creating slope hachures for large-scale maps:

1. Hachures follow the steepest gradient's direction.
2. Hachures are laid out in horizontal rows.
3. Hachure length is the local horizontal distance between two imagined contours of a certain interval.
4. For higher slopes, the hachure breadth is thicker.
5. The density of hachure remains consistent across the map region. (mtech.edu) Microsoft Word - hachure4.doc

To create large-scale hachure maps with vertical illumination, all of the preceding principles must be followed. Rule five is altered to produce hachures with the appearance of oblique lighting. More constraints are relaxed to allow for a freer graphic portrayal when creating hachures for a small-scale map, defined by Imhof (1982) as less than 1:500,000. The use of hachures is a traditional cartographic technique for displaying three-dimensional terrain on a two-dimensional map. In general, a fine line or hachure is drawn in the direction of the sharpest topographic gradient. Tonal variations are created throughout the map by hachuring throughout an area. These tonal changes are a type of analytical hill shading, and they help to create a three-dimensional picture of the topography. Such hill shading can be achieved by the use of vertical or oblique lighting techniques. Hachures show quantitative measures of the slope and aspect of the topography. The slope is the steepest topographic gradient's angle from horizontal, whereas the aspect is the azimuthal angle from north measured clockwise. Because hachures are quantitative representations of various topographic components, guidelines for their creation

have been created. The main rules differ based on whether the hachure is part of a large-scale or small-scale map, and whether the hachures are illuminated by theoretical vertical or oblique illumination.



Fig.2.1 Hachure lines

Benefits - The slope gradient of the surface is easily exhibited in this manner; at first glance, only the mounds and other minor information found in regular plains that are not displayed by contour lines are found.

Demerits -The actual altitude of a site is not displayed. Other supporting information is lost when lines are drawn too tightly. This procedure is more expensive and time-consuming.

2. Hill Shedding Method

This method depicts a pulse gradient by picturing hypothetical light as dark and light shadows. This method is also known as the plastic shade method. It appears to be a shadow shot taken from above when creating the model. Parts that fall in the dark are shaded, while parts that fall in the light are kept blank. The slope areas are dark, while the plain/flat areas are lighted.

Sharp slopes are black because of this, whereas ridge tops, plateaus, and plains are lighted and have less shadow. It comes in two varieties:

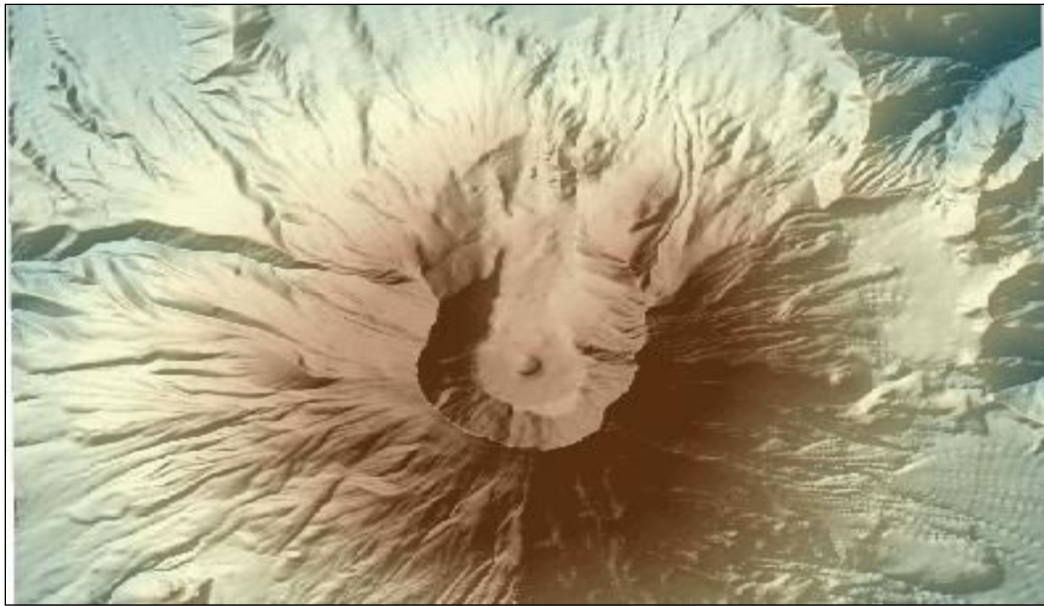

Fig. 2.2 Hill shading method

(A) Vertical Illumination Method - The shadow of light is visualised on the uppermost section of a region in this method. The black light casting a shadow on individuals standing, as well as light on the low slope and flat region.

(B) Oblique Illumination Method - In this method, light and shadow are visualized on the region map's north-west top. As a result, the state of disclosing the north-west branch is lighted by a light shade, while the state of revealing the south-east branch is illuminated by a deep shadow.

Benefits and drawbacks- The mountain shadow approach displays the general features of the surface. This strategy is superior to a large-scale map. This is useful for small-scale maps. This can be used to demonstrate cultural and economic facts. Mountainous areas are more conducive to filming. Because this is a qualitative method, it cannot provide knowledge of height, for example. Even awareness of proclivity is incorrect.

3. Trachographic Method-

The Relative Relief and Average Slope depicted on a map can be displayed using this way. A hill shaped curve is used to illustrate the relative surface because it gives an idea of the quantity average slope to the bottom and slope of the valley. The width and height of the curve change depending on the mean pulse and the relative ground level.

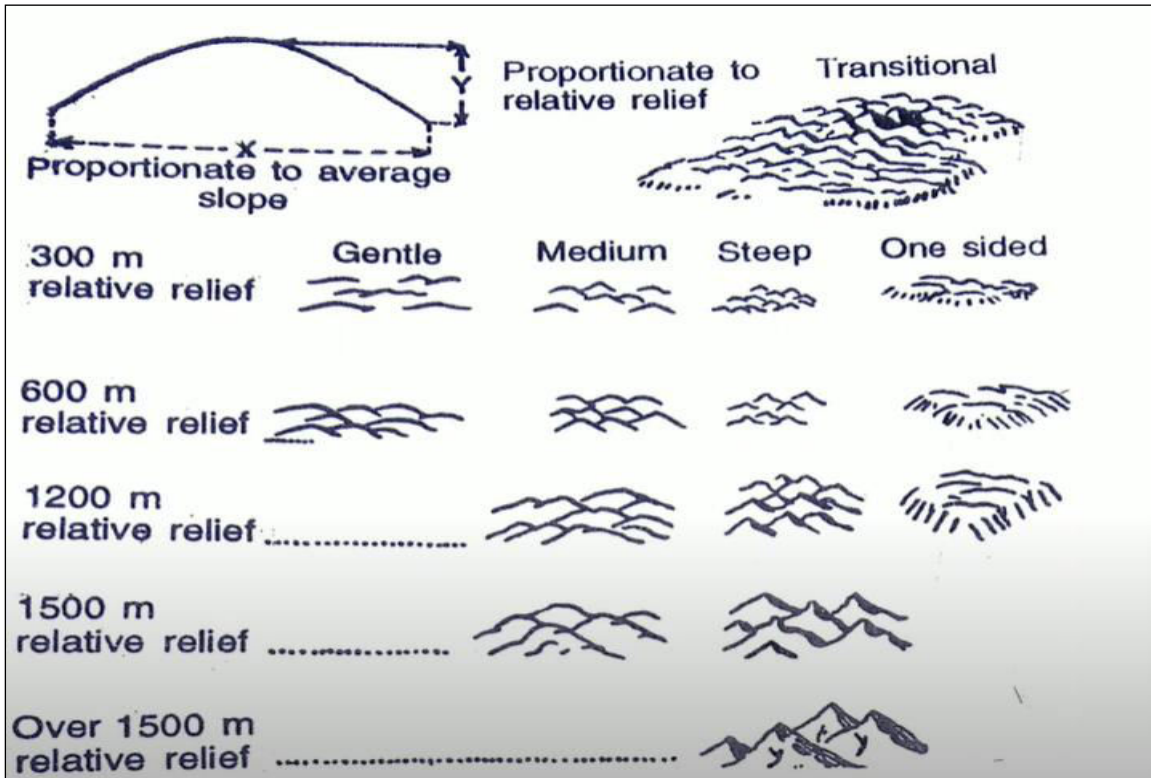

Fig. 2.3 Trachographic Method

4. Morphographic Method-

This is a method of expressing the landscape by using symbols that are similar to the properties of natural topographies. This approach was developed by A.K. Lobeck (A.K. Lobeck-1921) and Erwin Raisz in 1931. The topographical feature symbol is based on an aerial image taken at 45 degrees. This demonstrates the type of terrain.

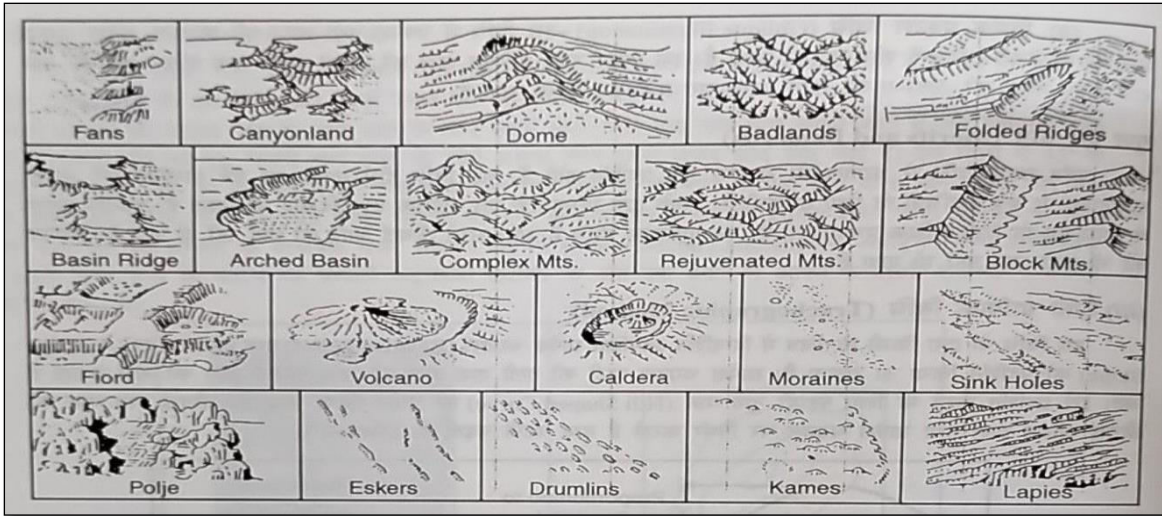

Fig. 2.4 Morphographic Method

2. Quantitative or mathematical method

The search for new techniques of representing relief features persisted as cartography advanced. France began its attempts in the eighteenth century. These methods are now widely used in the portrayal of relief. Spot heights are utilized in these approaches to determine the heights of a specific location or area. Contour interpolation using spot heights is possible, which aids in depicting relief with greater precision. The following are some of the mathematical methods used to depict relief:

1. Spot heights –

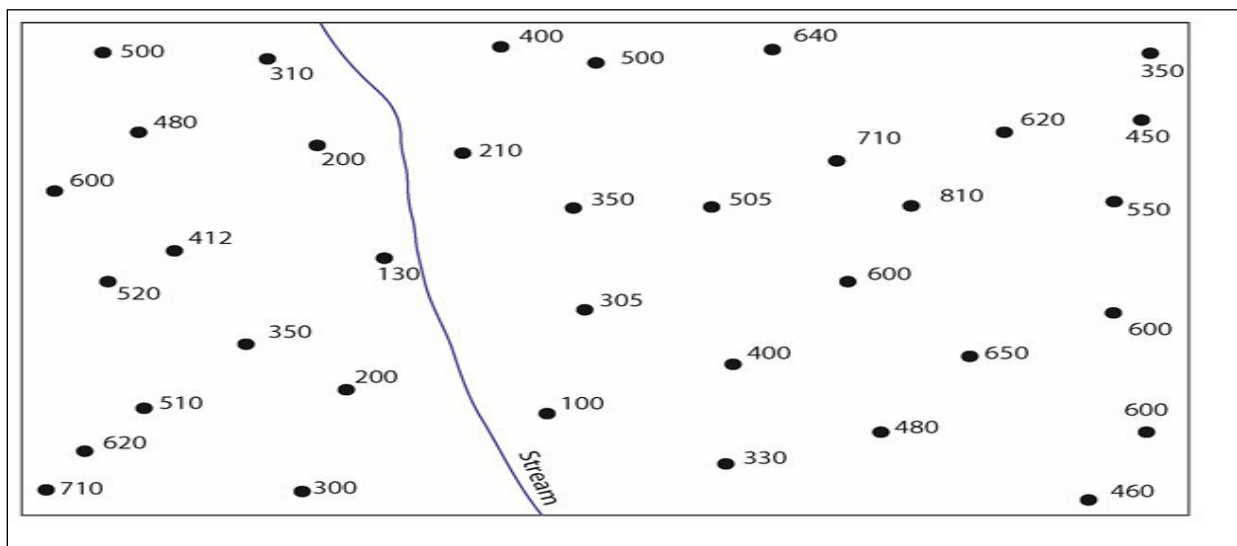

Fig. 2.5 Spot height

2. Bench Marks-

The term Benchmark refers to an item used to designate a spot as an elevation reference. They are:

1. Bronze or aluminum discs are frequently embedded in stone or concrete, or
2. on rods deep into the earth to create a permanent elevation point.

Benchmarks are often placed by a government agency or a commercial survey business, and many governments keep a register of these marks so that the records are accessible to all. These records are typically in the form of a geographically searchable database (computer or map based), with connections to sketches, diagrams, images of the markings, and any other technical details. Government entities that install and maintain records of benchmarks incorporate, at times, the abbreviation 'BM.' Benchmarks are inscribed within them, as indicated in the illustration.

3. Hill shading

Hill Shading (also known as 'Plastic Shading' in the United States) is a modern alternative to hachure's. Because of the ease of generalization and reproduction provided by lithography, a map made via hill shading appears to have light cast on it vertically downwards or from the side. Slopes appear darker in vertical light because they cover a bigger area. The darker the hill shading, the steeper the slope. A complete caterpillar represents a flat-topped or elongated ridge.

4. Trigonometric-Point Method

Base stations are established in the area at predetermined distances using this strategy. Spot heights are denoted with triangles at these locations. These stations can be several kilometres apart. When these stations are built, the curvature of the earth is also taken into account.

2.3.3 SLOPES AND GRADIENTS

A landscape's life history is influenced by its slope. It accounts for the drainage pattern and terrain modification, influencing the flora and fauna of the land as well as human habitation.

A slope is a condition in which one side of the ground is higher than the other. It represents declination. Gradient is a fractional representation of the actual degree of slope or declination.

Type of slope

Slopes are classified into four types:

1. Uniform
2. Convex
3. Concave
4. Undulating

1. In a Uniform slope

The slope remains consistent throughout. Equidistant contour lines depict such a slope.

2. A convex slope

An outward bulge indicates a convex slope. The slope is steep at the bottom but gentle towards the summit. It signifies that the slope is steeper at the bottom and less so at the top. As a result, the contour lines depicting a convex slope are close together at the bottom and considerably farther apart at the top. A convex slope distinguishes a dome-like hill or a narrow steep-walled valley.

3. A concave slope

An inward curve on a relief feature indicates a concave slope. The slope here is steeper at the bottom and gentler towards the summit. As a result, contour lines are far apart at the foot and close together at the summit. Concave slopes are represented by the wide valleys, which are both V-shaped and U-shaped.

4. An undulating slope

On a relief feature, combines both outward bulges and inward bends. It is a frequent element of nature that despises standardization. The contour lines in this case are variable spaced, which means that there is no consistent spacing between the succeeding contour lines.

1. Methods of expression of slope

Slopes are expression in (a) degrees, (b) gradient, (c) percentage and (d) mils.

(A) By degrees

Assume ABC is a right angle, with AC representing the slope angle, AB representing the vertical interval, and CB representing its horizontal equivalent trigonometrically.

$$\text{Tan } \theta = \frac{AB}{CB} = \frac{V.I.}{H.E.}$$

IF V.I. = 5 m and H.E. = 50 m

$$\text{Tan } \theta = \frac{5}{50} = \frac{1}{10} = 0.10$$

From the Trigonometrical Tables

The value of $\theta = 6^\circ$

(B) By Gradient

The gradient is the slope value given in times of fraction when the numerator is unity. It is the proportion of Vertical Height (V.I.) to Horizontal Equivalent (H.E.). If V.L. = 5 m and H.E. = 50 m, the gradient is $5/50 = 1/10$, indicating a one-meter climb in a horizontal distance of 10 meters.

(C) By Percentage

We may calculate the slope in % by multiplying the gradient by 100. A gradient of 1/10 corresponds to $\frac{1 \times 100}{10} = 10\%$. The same thing can be said as follows:

$$\text{Slope Percentage} = \frac{V.I. \times 100}{H.E.}$$

(D) By Mils

The army employs this slope unit. The slope in mils is ten times the percentage slope.

$$\text{Hence Slope in mils} = \frac{V.I. \times 1000}{H.E.}$$

If V.I. = 5 m and H. E. = 50 m,

$$\text{The slope in mils} = \frac{5 \times 1000}{50} = 100 \text{ mils}$$

Conversion of Gradient into Degrees of Slope and Vice Versa:

Case I: Finding the slope in degrees from a given gradient.

$$\frac{V.I.}{H.E} = \frac{5}{50} = \frac{1}{10} \text{ (Gradient)}$$

$$=0.10.$$

From the Trigonometrical Table

$$\tan 6^\circ = 0.10$$

Hence, the angle of slope is 6°

When the gradient is $\frac{1}{10}$

Case II: Finding the gradient from a given angle of slope.

To calculate the gradient from a given slope angle, divide it by 60 (or, more precisely, 57.3) and make the numerator one. If the slope angle is 6° , the gradient is $\frac{6}{60} = \frac{1}{10}$.

Angle of Slope	Gradient	Description	Remark
Less than 1°	$\frac{1}{60}$	Gentle	Steel Railway Gradient
1° to 3°	$\frac{1}{60}$ to $\frac{1}{20}$	Moderate	Cyclists walk
3° to 6°	$\frac{1}{20}$ to $\frac{1}{10}$	Stiff	Horse driven vehicles proceed at a walk
6° to 12°	$\frac{1}{10}$ to $\frac{1}{5}$	Steep	Cars find gradient difficult, have to change gear.
12° to 20°	$\frac{1}{5}$ to $\frac{1}{3}$	Very Steep	Horses descend obliquely on slopes greater than 15° and hand driven vehicles cannot ascended.
20° to 30°	$\frac{1}{3}$ to $\frac{1}{2}$	Extremely Steep	Limit for cars
Over 30°	over $\frac{1}{2}$	Precipitous	Man can ascend using his hands and feet.

Slope Determination Using Contours

The horizontal distance between the two contour lines must be determined before calculating the slope. Assume there are two places A and B on contours of 400 m and 500 m, respectively. The

vertical Interval (V. I.) between A and B is the elevation difference (100m). In this case, the slope will be represented by a gradient of $\frac{100}{500} = \frac{1}{5}$ or $\frac{1}{2} \times 60 = 12^\circ$ or $\frac{100 \times 100}{500} = 20\%$ or 200 mils.

Land-Slope Diagrams- The following are the key slope analysis methods:

2.3.4 WAENTWORTH'S METHOD:

C.K. Wentworth devised a simplified method for measuring the average slope of the land surface in 1930. The contour map of the area is divided into small squares using east-west and north-south grids, and all contour crossings are counted and tabulated to get the average contour crossing per kilometer. The process is then carried out using an oblique grid, and the average number of contour crossings per kilometer is obtained. The average of the two outcomes is now computed, and the tangent of the average angle of slope of the land surface is derived using the following data:

$$\tan \theta = \frac{A \times I}{3361}$$

Where θ = the average angle of slope

A= the average number of contour crossings per kilometer.

I= the contour interval

wentworth calculated the constant 3361 by calculating the mean of all possible sine values of the angle between the grid line and the contours. Calculated the constant 3361 by calculating the mean of all possible sine values of the angle between the grid line and the contours.

2.3.5 SMITH'S METHOD OF RELATIVE RELIEF

G.H Smith invented the Relative Relief Method in 1935 to create a land slope map of Ohio. The difference between the highest and lowest relief is referred to as relative or local relief. The topographic map is divided into 5' longitude and latitude rectangles, and the relative relief in each rectangle is computed by the difference between the highest and lowest locations and plotted on a small scale box map. Isoleths are drawn for each 25 m of relative relief by connecting points with even discrepancies, and tints between the isopleths are employed for

clarity. This approach has been used well to show maturely dissected plains and plateaus, but it has not produced adequate results when mapping complex topography.

2.3.6 PROFILE:

A relief profile is a line on a map that depicts the rise and fall of the ground's surface along a specific line. Drawing relief profiles is one of the more advanced techniques for representing relief. A relief feature profile serves as a visual assistance in its description and understanding. As a result, it is of particular interest to geographers, particularly geomorphologists, who are interested in the examination of landforms and the processes of their upkeep and degradation. Identifying landform characteristics with contours is difficult, however profiles are reasonably simple and beneficial in comprehending relief features. In general, a profile, sometimes known as a section, is an outline of a relief (elevation or depression) along a certain line. However, a distinction is sometimes established between a segment and a profile. A section is typically a cutting made for a geological section, whereas a profile is an outline of a surface relief feature, such as a river valley profile.

Types of profiles

To accurately portray the relief, various types of profiles are created. The following are some key passages:

1. Longitudinal Profile - This profile is drawn from a river's headwaters to its mouth. It depicts the slope of the river valley from its headwaters to its mouth. The river's childhood, adulthood, and old age are plainly visible. These stages can be found in the river's upper, middle, and lower courses. A rail track or a road can also be used to create longitudinal sections. The most difficult aspect of creating a longitudinal section is converting a river's, railway line's or road's zigzag route to a straight line basis. This challenge is solved by segmenting the entire route and marking it on a straight line basis.

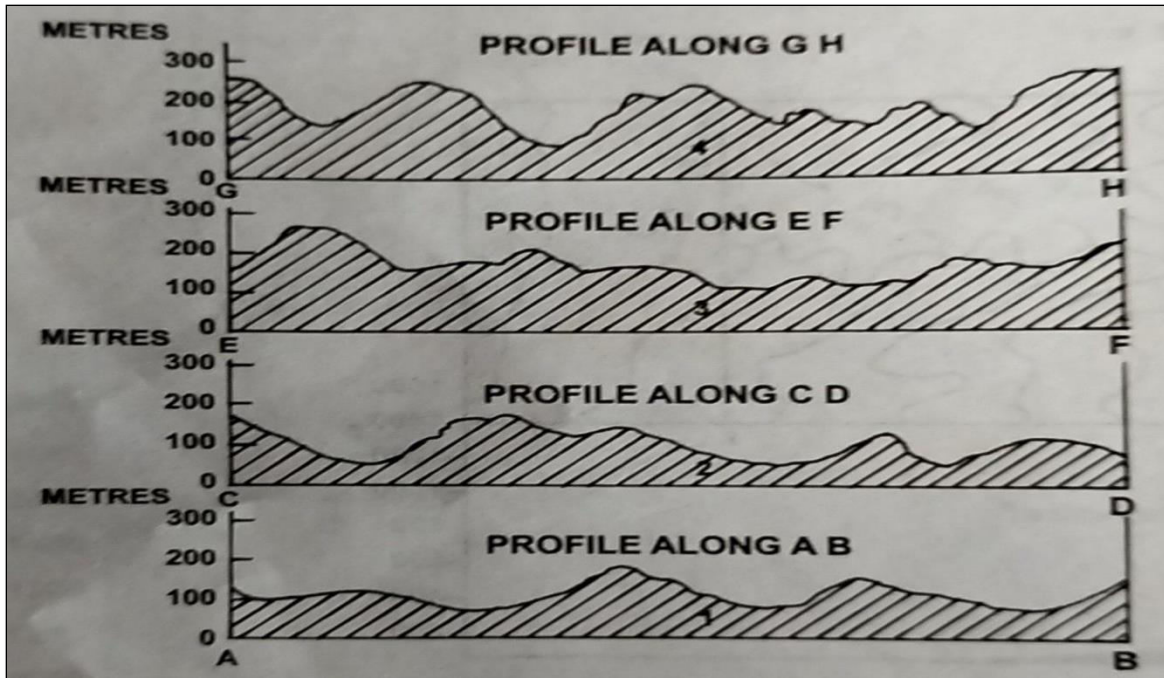

Fig. 2.6 Serial Profiles

2. Transverse or Cross Profile - It is drawn perpendicular to the direction of a river's water flow across its valley. This accurately depicts the shape of the river valley. Three cross-sections are drawn over the river valley in Fig. 22.54 to highlight the outlines of the river valley in its higher, middle, and lower regions. Transverse sections are also drawn across a mountain, plateau, or ridge, among other things.

3. Serial / Simple profile: These are created by sketching a series of profile or parallel profiles to illustrate features such as a coastline, plateau borders, a succession of spurs, a transverse profile of a river, a junction of two contrasting topographical features, and so on.

4. Superimposed Profile: A superimposed profile is one in which a succession of profiles are placed on a single plane. These subsequent profiles are numbered for clarity. Such profiles are commonly employed to portray landscapes with a high degree of morphological regularity.

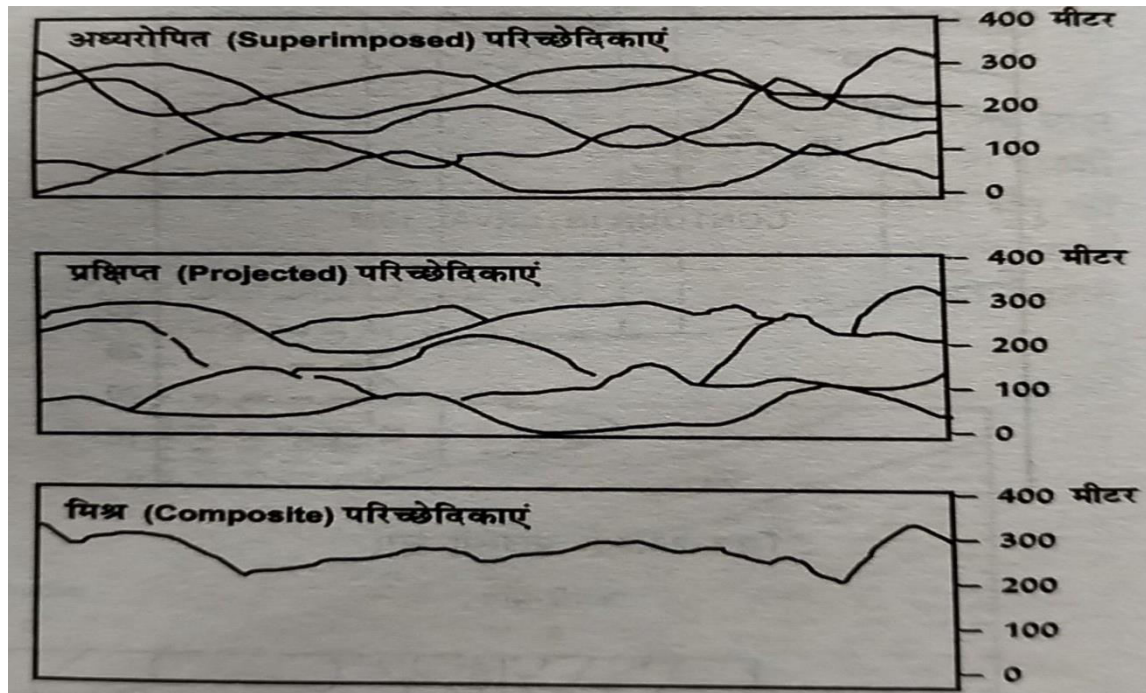

Fig. 2.7 Superimposed, Projected and Composite Profiles

5. Projected Profile: The successive parallel profiles in the superimposed profiles are put on a similar base line. The lowest parts of the profiles, however, are obscured behind the higher intervening heights. When only the viewable portions of subsequent profiles are displayed on a similar framework, a panoramic view of the foreground, middle ground and sky line is obtained. Profiles of this type are known as projected profiles or compressed profiles.

6. Composite Profile: If the overlaid profile of a landform is properly examined, one can identify a summit line, the skyline, at the farthest end of such a profile, which provides a basic outline of the concerned landform features as viewed from a distance. A profile or a line produced by combining the highest portions of a series of parallel profiles can be used to illustrate this skyline. This type of profile is known as a composite profile. Such profiles can be used to compare topography types within a region or between regions.

2.4 SUMMARY

Relief feature portrayal on maps has always been difficult because there is always opportunity for improvement. The art of map construction evolved over time from surveyors' notes and local sources, and various methods of displaying relief features on maps were also developed.

Map representation of the earth's surface has limitations. Short lines were drawn down slopes in the direction of the sharpest gradient to begin relief representation and slope analysis. These are known as Hachure. These lines were unable to detect the precise height of the points or locations, as well as the precise slope and slope values. Contour lines were later created to solve a problem. Contour lines can also be used to calculate exact slope angles. This is accomplished by calculating vertical angles and horizontal distances between two points on a map. Between the contours, regular intervals are drawn. For numerous reasons, "topographic maps" are widely used as base maps to display various relief elements of the earth's surface. These maps show a variety of features. A spot height is a unique location on a map with an elevation recorded above a certain datum, which is frequently mean sea level. Bench Marks are used to mark a location for elevation purposes. The map-making process refined pictorial presentation, hill shading, layer shading, and coloring over time. High-quality maps that show relief features in an appealing manner are being produced using enhanced computer-based cartography and the use of aerial and satellite pictures, aerial photography, and photogrammetry, allowing for a more clear and effective portrayal of the environment. A digital elevation model (DEM) is a raster-based digital dataset that displays the topography of the entire Earth's surface or a segment of it. GIS and remote sensing techniques can be used to build DEMs from existing topographic maps and survey data. Contours, on the other hand, are one of the most essential media for portraying relief characteristics on the earth's surface, and they are used in all other sophisticated approaches.

2.5 GLOSSARY

Hachure: A short line drawn in the direction of the slope for shading and denoting surface in relief (as in map drawing).

Hill shading: On a map, a shaded relief (level of grey) to depict relative slopes and mountain ridges rather than absolute height.

Layer shading: Often known as layer coloring, is a method of displaying elevation variations on a map. It is used in the same way as contour lines are used on maps to depict larger areas, such as entire countries.

Photogrammetry: Photogrammetry is the use of photographs in surveying and mapping to determine distances between objects.

Triangulated irregular network (TIN): A digital data structure used to describe a surface in a geographic information system (GIS).

A digital elevation model (DEM): is a three-dimensional (3D) representation of the surface of a planet (including Earth), moon, or asteroid produced from topographical elevation data.

Geographic Information System (GIS): A system for capturing, storing, manipulating, analyzing, managing, and displaying all forms of spatial or geographical data.

Relative relief: The difference between the summit level, which is the highest altitude for a particular area, and the base level, which is the lowest altitude for a given area.

A drainage pattern: The shape generated by the streams, rivers, and lakes in a specific drainage basin. They are determined by the land's topography, whether a particular location is dominated by hard or soft rocks, and the land's gradient.

2.6 ANSWER TO CHECK YOUR PROGRESS

(Self check Questions)

1. What exactly is a contour?
2. What are the features with the highest relief?
3. What exactly are hachures?
4. Where did the term "topography" come from?
5. Why is relief mapping useful for geographers?
6. What kind of geographical studies benefit most from relief research?
7. What exactly is local relief?
8. Explain what a digital elevation model (DEM) is.
9. What processes are responsible for the various sorts of relief features on the surface?
10. What do you mean by "relief"?

11. Why is it so difficult for geographers to depict the irregularities of the earth's surface on plain paper?

12. Fill in the blanks with appropriate words from below.

1. Earth features are.....in elevation

2. Geographers have divided land forms into..... orders of relief.

3. Methods of showing relief largely depend upon the..... of the map.

4. The.....maps show the earth features more precisely.

5. All portions of the terrestrial surface have..... relief, scale, different, three, large- scale.

(Answers to self-check Questions)

1. A contour is a line drawn on a map that connects all points that have the same height above mean sea level.

2. The highest elevation points are usually mountains and ridges.

3. Hachures are little lines that are drawn down slopes in the direction of the sharpest grade.

4. The term topography originated in ancient Greece and was used as a thorough description of a location in ancient Rome.

5. Geographers must study relief because it determines the horizontal and vertical dimensions of the earth's surface. It has an impact on various elements of human life. Relief can alter hydrological and climate trends that are studied in geographical studies across a vast area. That is why it has piqued the curiosity of geographers.

6. Relief studies aid us much in agricultural activities such as contour farming. This leads to more sustainable farming on hill slopes. The relief of that particular place influences weather variations and the establishment of climatic regions to a large extent. Aside from that, relief determines various actions connected to human society's evolution.

7. Local relief is the quantifiable assessment of vertical elevation change in a specific location.

8. A digital elevation model (DEM) is a raster-based digital dataset that depicts the topography of the entire or a portion of the Earth's surface.

9. The many forms of relief characteristics on the earth's surface are caused by the complicated combined effect of the dynamic processes functioning in that specific section of the earth's surface.

10. Relief refers to the difference in elevation. Altitude, the third dimension of geographical space, is one of the most noticeable abnormalities of the Earth's surface.

11. The earth's surface is three-dimensional, with length, width, and height, whereas maps only contain two dimensions (length and width). Geographers have traditionally struggled to depict the imperfections of the earth's surface on planar paper.

12. 1. Earth features are **different** in elevation.

2. Geographers have divided landforms into **three** orders of relief.

3. Methods of showing relief largely depend upon the **scale** of the map.

4. The **large-scale** maps show the different earth features more precisely.

5. All portions of the terrestrial surface have **relief**

2.7 REFFERENCES

1. Dikinsion, G.C., (1963): Statistical mapping and the presentation of Statistical data, London

2. Mahmood, A. (1977): Statistical Methods in Geographical Studies, Rajesh Publication, New Delhi

3. Mishra, R. P. and Ramesh, A., (1969): Fundamentals of Cartography, Concept Publication, New Delhi.

4. Monkhouse, F. G. and Wilkinsion, H. R. (1956): Maps and Diagrams, Metheun, London.

Robinson, A. H. and Sale, R. D., (1969): Elements of Cartography,

5. Robinson, A. H. and Sale, R. D., (1969): Elements of Cartography,

6. Singh, L. R. and Singh, R. L. (1991): Map work and Practical Geography, Indian University Press, Allahabad. Pp 165-203

7. Singh, R. L. and Singh Rana, P. B. (1991): Elements of Practical Geography, Kalyani Publishers, Ludhiyana.
8. Wilkinson, Harland Moonkhouse, F. J. (1952): Map and Diagrams, B. I. Publications pvt. Ltd. New Delhi.
9. Dr. S. C. Bansal., Meera Villa, D.S.O. Coppound, Court Road, Saharanpur-247001.
10. <https://en.m.wikipedia.org>
11. [https:// www.google.co.in](https://www.google.co.in)
12. [https://en](https://en.wikipedia.org) Wikipedia.org
13. https://en.Wikipedia.Org/wiki/Sea_level

2.8 TERMINAL QUESTIONS

1. Establish benchmarks and spot heights.
2. What role does hill shading play in the rendering of relief?
3. Describe quantitative methodologies. Define their position in relief representation.
4. Which relief features on the earth's surface are plainly identified by contour lines on maps?
5. What exactly is the Layer colouring method?
6. How does this strategy apply to the representation of relief?
7. Can you determine the slope of a region using contour lines? Explain.
8. Describe the computer mapping methodologies. Define their role in relief rendering.
9. Describe photogrammetry as a cartographic technique.
10. How important is relief representation to geographers?

UNIT-3 CLIMATE MAPS AND DIAGRAMS: CLIMATE MAPS AND DIAGRAMS, REPRESENTATION OF CLIMATE DATA: ISOPLETHS, COLUMNAR DIAGRAM, WIND ROSE DIAGRAMS, RAINFALL DISPERSAL, HYTHERGRAPH AND CLIMOGRAPH.

3.1 OBJECTIVES

3.2 INTRODUCTION

3.3 REPRESENTATION OF CLIMATE DATA-

3.3.1 ISOPLETH DISPERSION DIAGRAM

3.3.2 DIAGRAM WITH BARS OR COLUMN

3.3.3 WIND ROSE DIAGRAM

3.3.4 RAINFALL DISPERSION DIAGRAM

3.3.5 CLIMOGRAPH

3.3.6 HYTHERGRAPH

3.4 SUMMARY

3.5 GLOSSARY

3.6 ANSWER TO CHECK YOUR PROGRESS

3.7 REFFERENCES

3.8 TERMINAL QUESTIONS

3.1 OBJECTIVES

After having the detailed study of this unit you will be able to:

- To comprehend how to portray temperature, wind, humidity, and rainfall data, as well as other atmospheric factors that describe the local weather and environment.
- Recognize the interdependence of those components in various sections of the earth's surface.
- Identify changes in the atmosphere and represent the consequences of various weather occurrences using appropriate methodologies.
- To comprehend weather events and the resulting climate changes in the most efficient and effective manner possible.

3.2 INTRODUCTION

The climate of any given location or country piques the curiosity of geographers, geologists, and climatologists all around the world. Scientific investigations over the last few decades have revealed that the global climate is changing in such a way that human survival may be jeopardized. The pattern of human life in every particular place is heavily influenced by the climate of that region. The world's geography, economy, and society will undoubtedly alter as a result of global warming. As a result, altering climate patterns all across the world are a source of concern for scientists and researchers in various parts of the world today.

It is vital to comprehend what is meant by the term weather in order to properly grasp climatic conditions all across the world or in a specific place or region within it. Weather is simply the current state of the atmosphere at any particular moment and location. You are well aware that some places are dry, some are wet, some are hot, some are cold, and the rest are varied, with a complicated blend of different types of weather.

Looking out the window or going outside will tell you what the weather is like where you live. In everyday conversation, you might question a cousin or friend about the weather in his or her location. Temperature, humidity, cloudiness, visibility, different types of precipitation, and wind direction and speed are all examples of weather. To understand better, remember that the five factors listed above determine the state and condition of the atmosphere, and so influence

and determine the weather. Weather exists in every location on the planet. However, weather often differs over the Earth's surface. Weather scientists collect data from various locations on the planet and calculate averages, or typical forms of weather, for each location. They encompass the current state of the atmosphere in a region as well as its variations. The distinction between weather and climate, which students frequently misinterpret, is thus rather straightforward. Weather provides information on the atmospheric conditions at any given time by measuring pressure, temperature, wind speed and direction, humidity, precipitation, cloud cover, and other variables in real time. Thus, weather can be defined as the daily state of the atmosphere and its short-term change.

Weather has a direct impact on your daily life, and you may analyze its impact on a wide range of areas, including the social and economic well-being of people in their communities. When organizing a journey or outing, the first thing you ask yourself is about the weather conditions of the destination so that you can carry your luggage suitably. Now tell us about the weather. Climate is statistical weather information that describes the variance of weather at a specific location throughout time. Thus, climate comprises weather conditions for a certain region over time. Climate determines the mean values of weather elements over a relatively larger area and over a longer period of time. In common parlance, climate is a synthesis of weather; more officially, it is the weather of a location averaged over 30-40 years, with statistics on weather extremes. As a result, they are sometimes used interchangeably but differ in terms of the amount of time they measure and the patterns that affect them. The climatic conditions of a location have a direct impact on the ecology of that region, including flora and wildlife. Climate has an impact on the dwellings people live in, the clothes they wear, and, to some extent, the recreational activities in that area.

Analyzing climate data entails looking for trends, relationships, and linkages. Meaningful patterns or processes develop as you analyze and understand data. After that, you can combine your observations to form coherent explanations. Throughout the process, you should take note of links and similarities across places, recognize patterns, and make conclusions from maps, graphs, diagrams, tables, and other sources. You will be able to look for patterns, relationships, and sequences using basic statistics. Various procedures are involved in climate analysis.

It can be difficult to differentiate the processes involved in organizing meteorological information from the procedures needed to analyze it; in many circumstances, the activities occur concurrently. In other cases, analysis follows the transformation of raw data into a more understandable and useable format. However, climatic data interpretations require the usage and development of spatial climatic data. Meteorological warnings and forecasts are very important to people and must be conveyed properly if they are to be useful to users. Weather conditions and climatic data are represented using various graphs and diagrams. Rapid technological advancements, on the other hand, have a huge impact in the field of graphics. On the one hand, advances in computer technology enable the creation of a vast array of graphic material; on the other hand, there is a need for formal training to produce expertise in graphics and to train individuals with capabilities that can aid in the representation of climatic data with computer cartography. With the information provided at a specific time in a specific area, skilled personnel may guide more efficiently and assist in the development of graphics to meet the unique needs and conditions of a specific area. Thus, in this section, we will explore some of the most essential climate diagrams from the beginning to the end.

3.3 REPRESENTATION OF CLIMATIC -DATA

The weather describes the atmospheric conditions at the specific place at a specific point in time. Climatic conditions of a particular place on the earth or the planet as a whole is determined by collecting meteorological data, real time measurement of atmospheric pressure, temperature, wind speed and direction, humidity, precipitation, cloud cover, and other variables. After knowing weather statistics for over periods of 30 years, you can determine the climate of your region.

Weather generally includes sunshine, rain, cloud cover, wind, hail, snow, sleet, freezing rain, flooding, blizzards, ice storms, thunderstorms, steady rains from a cold front or warm front, excessive heat, heat waves and more. Major weather phenomena are as follows:

The first and most significant factor that determines weather is temperature. Temperature is measured using a thermometer in degrees Fahrenheit or Celsius.

The second factor is air pressure that includes the amount of pressure exerted by the air in a particular air mass. Air pressure is also called barometric pressure because it is measured using a barometer and commonly measured in inches of mercury.

The third factor that can determine the weather is if place is experiencing humidity. Humidity is measure of the water content of the air mass.

Weather instruments are used to take measurements of temperature, wind, humidity, and rainfall, as well as other atmospheric factors that describe the local weather and climate. Different types of instruments are used to measure different parameters and there are many types to choose from. The variable measured with these types of instruments are wind speed and direction, pressure, humidity, temperature and precipitation, including rain and snow. For representation of weather- data it is necessary to view certain parameters in certain place. The user can define the month or season and place of interest. The weather data including past weather conditions and long term averages can be used for representation through various methods. Some of the methods with the help of which you can represent these data are given below:

3.3.1 ISOPLETHS DISPERSION DIAGRAM

The term 'Isopleths' is synonymous with the English word 'Isopleths,' which is derived from the Greek terms 'ISOS' (equal) and 'Plethos' (measure), and literally means a line of equal value. Lines connect points on a map that have a comparable value or density of an element or entity. Similar lines can be found in Quantity or Intensity. The primary isotherms are isotherms, isobars, isohyets, contours, isobaths, isoseismal lines, isonephs (isochrones), and so on. Isotherms have been given several names by different researchers. They are referred to as isorithms by European writers. John. K. Right, commonly known as isorithms.

Distribution maps, like contour lines, are created using many types of isolines. To create a respect map, first write the known quantities or values of an object in the map in the same manner that a contour map is done. This is where we write the spatial elevations. The more data and location information we have, the more accurate the scale map will be. After recording the place values or quantities, they are interpolated by picking appropriate intervals and plotting the isomorphism lines on the map. The difference between the highest and minimum values

presented on the map, the quantity and kind of the data, and the unit of the isthmus lines are all kept in mind while doing so. The isthmus lines are interpolated similarly to the contour lines.

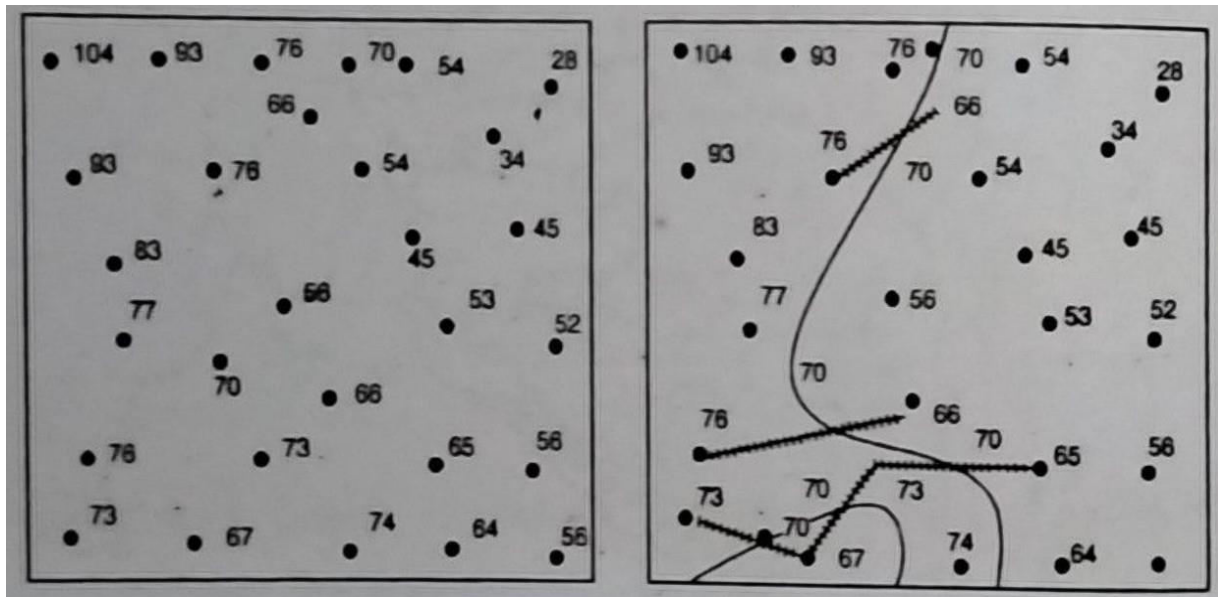

Fig. 3.1 Isopleths Dispersion Diagram

Isoclines technique advantages

1. It is the most accurate scientific approach of demonstrating distribution. It has nothing to do with administrative units.
2. The slope of an element can be determined by the direction in which it changes.
3. The isoclines approach makes displaying regional distribution simple. Temperature, rainfall, air pressure, and other climatic factors are represented as point data. This is demonstrated by isotherm, isotrope, and news.

Isoclines technique disadvantages

1. Drawing isoclines requires interpolation, which is a difficult process.
2. The accuracy of isoclines maps is determined by the amount of spatial data available, because the more data available, the higher the accuracy.

3. Because the isometric map is more important when the gradient is low, this strategy is ineffective when there is a substantial change in the distribution. Because of the minor change in the climate data, this strategy is more appropriate.

3.3.2 Diagram with bars or columns

The display of data using a bar diagram is fairly simple and straightforward. This bar or column can be kept vertical or horizontal. The column's lines are all straight. Their widths are same. In accordance with the length scale. It is constantly reducing and increasing. It should be noticed that these columns are retained at their appropriate lengths while creating the design. On one side, the largest, then smaller, then smaller, and ultimately the smallest.

This method is used to depict the production, distribution, consumption, import, and so on of a single commodity in a certain area.

When drawing a bar diagram, the following rules must be followed:

1. All pillars or bars should be the same thickness.
2. There is no set method for choosing the thickness of the bars, but the bars should be thick enough to make the diagram look appealing while keeping in mind the number of item values and the size of the paper.
3. All of the bars in the diagram should be the same distance apart, which should always be less than the thickness of a bar.

Example: Create a simple bar graph using the data below.

Sex Ratio in India, 1901- 2011

Year	No. of females for every 1000 males
1901	972
1911	964
1921	955
1931	950
1941	945
1951	946

1961	941
1971	930
1981	934
1991	927
2001	933
2011	940

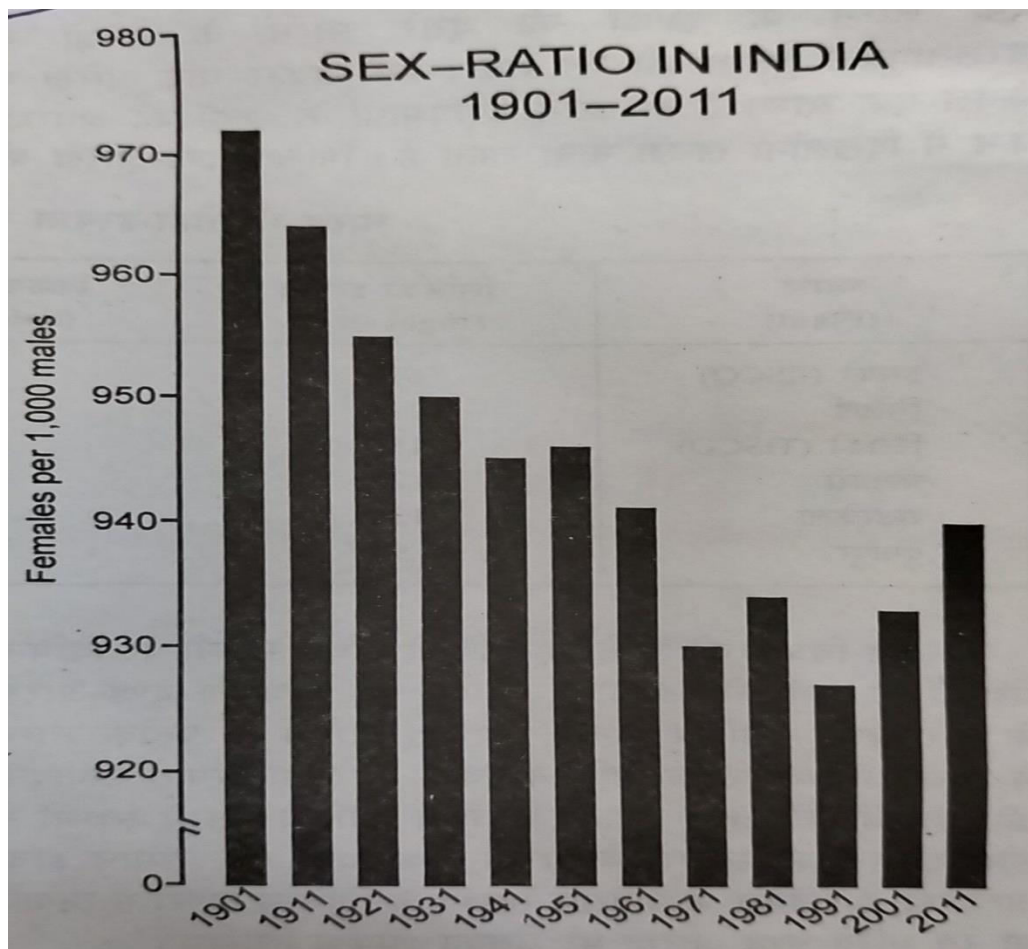

Fig. 3.2 Sex ratio in India

3.3.3 WIND ROSE DIAGRAM

A star diagram is used to show the direction of the prevailing wind at a place throughout the year. Its shape resembles that of a star, due to which it is called a star diagram. The values in

this diagram need to be represented as vector values along the radii from the center; For example, Wind rose, these are also called Clock Diagrams, Rose or Vector diagram. Star diagram shows the days of the period of wind moving in a particular direction. It also refers to calm days or days in which the wind does not blow. The number of quiet days is written in a small circle in the center of this diagram. Star diagrams are mainly of the following types

(i) Wind Rose Diagram

(ii) Simple Star Diagram

(i) Wind Rose Diagram -This is the easiest and most useful diagram; it shows the direction of the wind blowing on different days or months of the year.

To construct this diagram, draw a small circle and write the number of calm days in it. Then draw straight lines in the given directions at the center of the circle. Choose an appropriate scale and draw each line from the circumference of the circle in that direction. Label the days of the wind. Name each direction and draw a scale below the diagram.

Example- Draw a wind diagram of Chennai with the help of the following data.

Wind direction	N	NE	E	SE	S	SW	W	NW	Calm
No. of Days	36	41	55	79	19	20	91	22	2

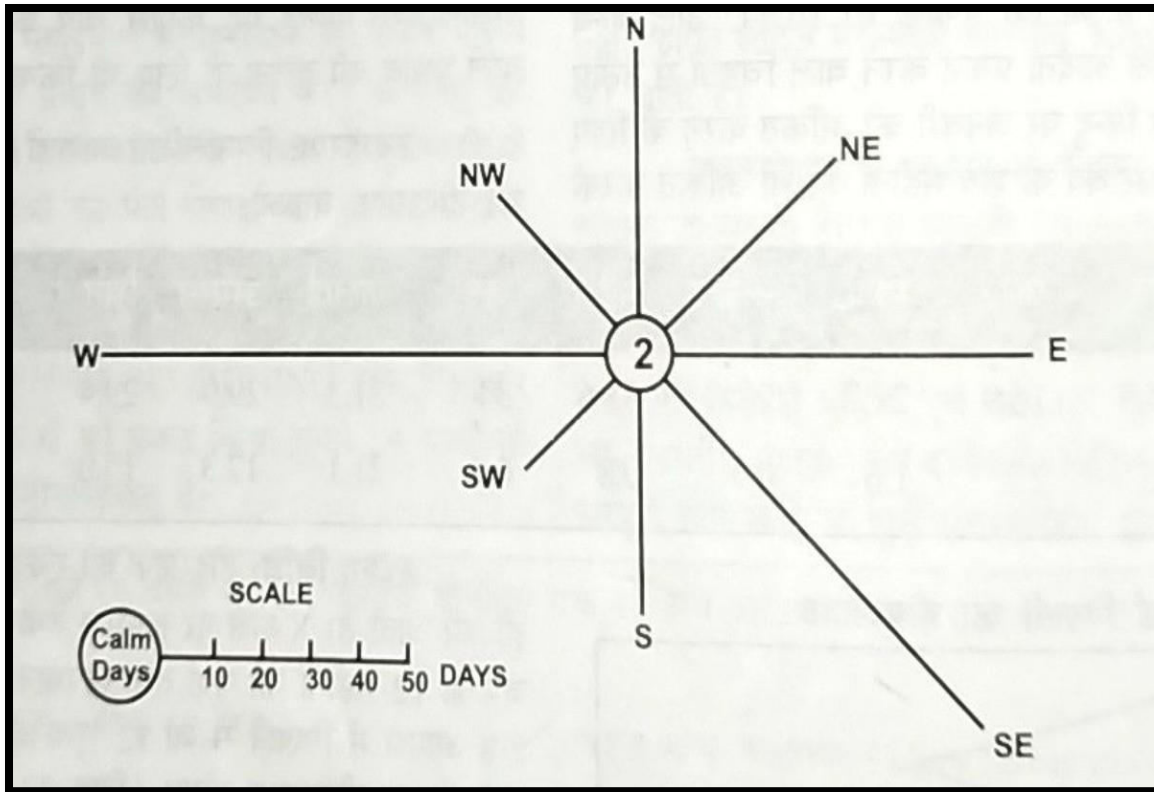

Fig. 3.3 Wind rose diagram

(ii) Simple Star Diagram- As the name suggests, it is a simple diagram to show the direction of the winds. To construct it, join all the eight directions of the wind diagram with straight lines. In this way an octagonal shape will be obtained. It looks like a star, due to which it is called a simple star diagram.

Through this diagram, the wind that blows at a place throughout the year the number of direction and the number of calm air are revealed. i.e. air how many days from which direction did it move and for how many days was it calm? In this diagram calm wind is shown by making a small circle in the centre and according to the measurement of the direction of wind, it is shown in each direction. The octagonal diagram. It is called Star Diagram. In this diagram the eight directions of the wind North, North East, South, South West and North West are revealed. When needed all the eight directions like North-North-East, North-East etc. can also be shown.

Example- With the help of the following data makes a star-diagram of Delhi.

wind direction	N	NE	E	SE	S	SW	W	NW	Calm
No. of Days	33	22	24	29	17	16	102	101	21

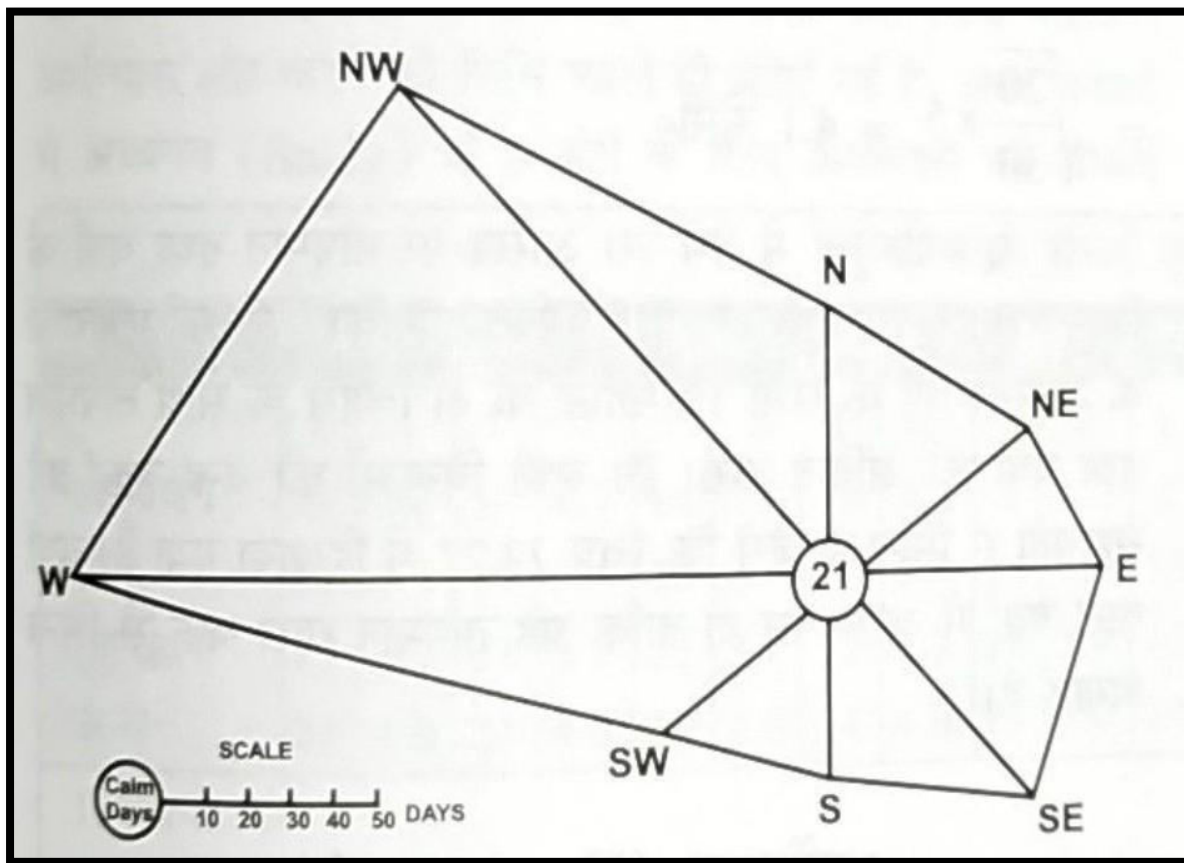

Fig. 3.4 Simple Star diagram

3.3.4 RAINFALL/DISPERSION DIAGRAM

This diagram is made like a bar diagram to analyze the distribution of rainfall. Rainfall Dispersion diagrams. Month wise maximum rainfall at a place based on the projection of its last 30-35 years period by maximum, minimum, median, lower quartile, tertiary/highest upper quartile values are displayed. In this diagram, rainfall on the vertical axis and twelve months are marked on the horizontal axis. Rainfall amount column by point for each month is marked in

median-value of rank in $N+1/2$, first/lower quartile for each month (Lower Quartile) = value of $N+ 1/4$ term and Upper Quartile (Upper Quartile) = $3 (N+ 1)/4$ term Let's calculate the value. From the above method, the values of the median, first and third quartile is determined for each month. After doing this, make vertical columns on the paper of equal thickness and at the same distance from each other.

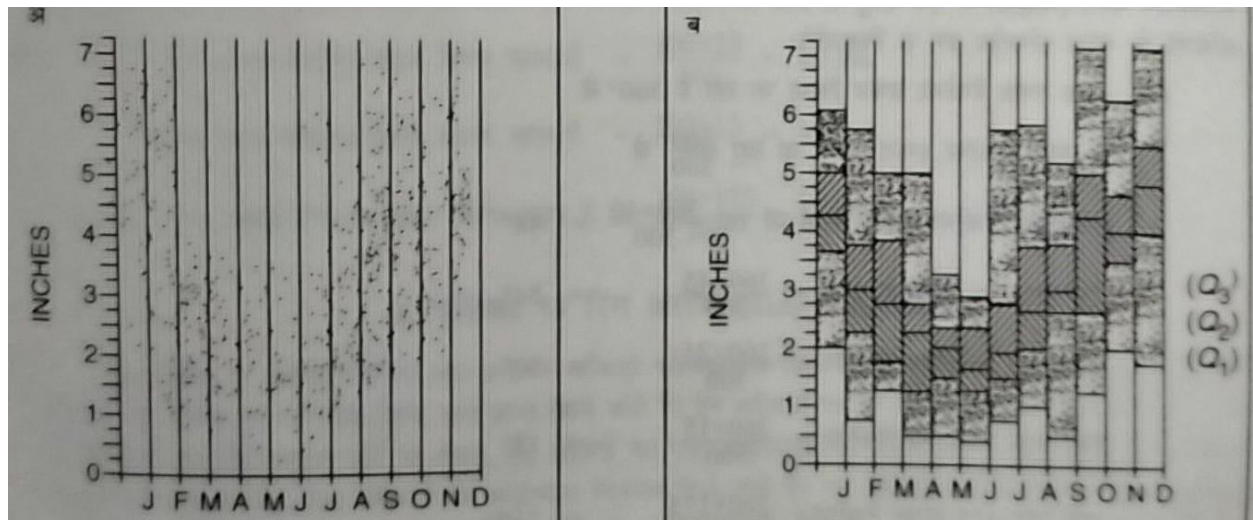

Fig. 3.5 Rainfall Dispersion diagram

CLIMATIC LINE GRAPH

Climatic diagrams In addition to the above diagrams, there are also some such diagrams which are used to represent climatic data. Climograph and heather graph are two prime examples of this.

Climograph “Climograph (or climogram) is a diagram in which the data of climatic elements of a place are plotted against each other and the shape and position of the resulting graph provide an indication of the general characteristics of the climate of that place.

In relation to the climograph, such ideas were first expressed by Jay Ball in the year 1910. In 1918, W. Köppen used the climograph to study the climatic division of the world. Köppen made a chart using the minimum and maximum temperatures of the coldest and warmest months of the year. In 1926 J. B. Lally developed Köppen's ideas and made climographs using which the climate found in different parts of the world could be compared. Around the same time, Griffith Taylor made a climograph with the help of which the climate conditions could be measured by

humans. The impact on the activities of the could be studied. After this, E. Foster, Huntington and Irwin Rays also made climographs.

3.3.5 CLIMOGRAPH

Dr. Taylor made a climograph using wet bulb temperature relative humidity. They showed relative humidity from 20 to 100% on the X-axis and wet bulb temperatures from -10°F (-23°C) to 90°F (32°C) on the Y-axis. On this graph, 12 points are plotted showing the relation of wet bulb temperature and relative humidity of 12 months of the year. At each point, the full name of the month related to it or in case of space shortage, the first letter of the name of the month is written. Months are also identified by writing numbers from 1 to 12. After this, the point representing the month of January is joined with the point of the month of February by a straight line, and the point of February is joined with the point of March. This sequence is continued till the month of December and finally the point of December is merged with the point of January. Thus we get a closed twelve sided figure on the graph.

In fact, Dr. Taylor designed the climograph to study the effect of climate on the human body. Its main objective was to find out the possibilities of Europeans' residence in tropical regions. That's why four words were used at the four corners of this graph. The general conditions of the climate were expressed by writing the words MUGGY, RAW, KEEN, and SCORCHING at the north-east, south-east, south-west and north-west corners of the graph, respectively. Following are the meaning and importance of these words

MUGGY: Warm and humid (humid) climate with a wet-bulb temperature of 60°F (15.5°C) and a relative humidity greater than 70%.

RAW: Cold and humid climate. Wet bulb temperature less than 40°F (4.4°C) and relative humidity greater than 70%.

KEEN: cool and dry climate. Wet bulb temperature less than 40°F (4.4°C) and relative humidity less than 40%

SCORCHING: Hot and dry (scorching) climate. Wet bulb temperature greater than 68°F (15.5°C) and relative humidity less than 40%.

By looking at the condition of the climograph, the climate of a region can be estimated with the help of the above four words. For example, if the climograph of a place is located in the north-west corner, then the climate there will be hot and dry i.e. desert with scorching weather. It is represented by a corner with cold desert climate (Keen).

Climate can also be estimated by looking at the shape of the climograph. Spindle shaped climograph. Shows dry continental climate. Diagonal climograph. From north-east to south-west shows the climate and diagonal climograph. from north-west to south-east shows the equi-oceanic climate. The British Isles equivalent climate is represented by the climograph. Across the whole.

Example: Draw a climograph of jodhpur with the help of following data:

Month	Jan	Feb	Mar	Apr	May	Jun	Jul	Aug	Sep	Oct	Nov	Dec
Wet-bulb temperature (°C)	14	16	15	19	18	25	25	25	24	20	16	15
Relative humidity (%)	27	39	23	22	28	43	49	55	48	21	14	26

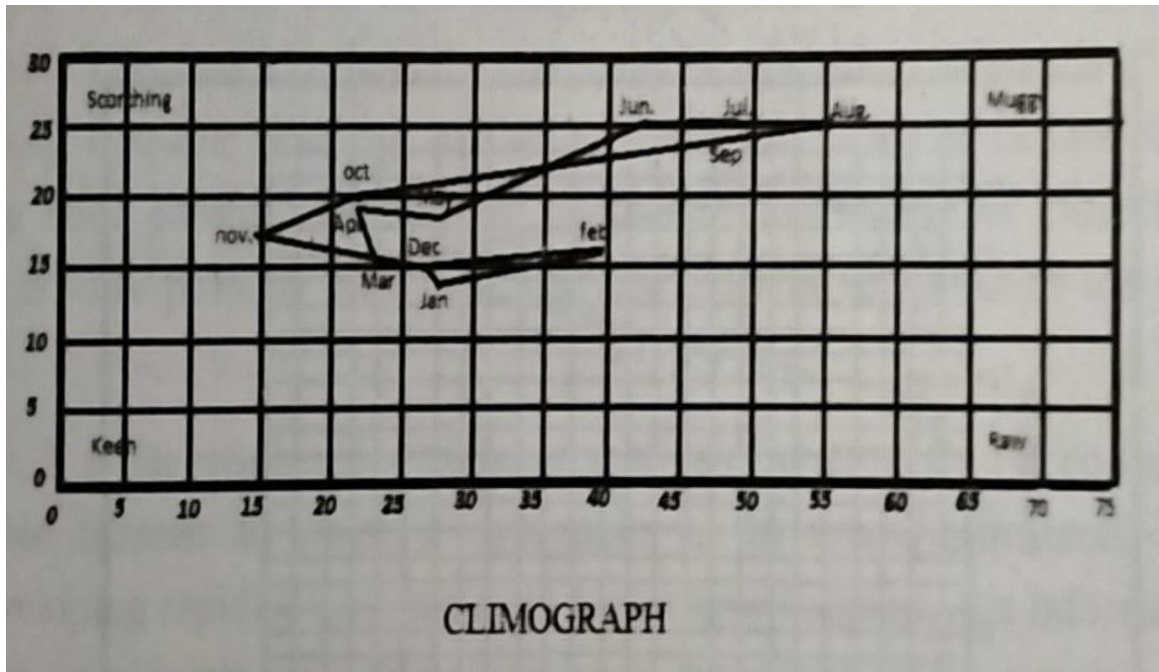

Fig. 3.6 Climograph

Choose suitable scale to represent relative humidity along the X-axis and wet bulb temperature along the Y-axis. Draw the co-ordinate of 27 % (relative humidity) 14° c (wet bulb temperature) to mark the point 'J' for January for Jodhpur. Similarly, mark the remaining eleven points. The twelve-side polygon so obtained is the climograph of Jodhpur. Now write down Scorching, Muggy, Keen and Row in their respective corners.

3.3.6 HYTHERGRAPH

The credit for the creation of Hythergraph also goes to Griffith Taylor. Its composition is also done like a climograph. The difference is that in a Hythergraph, the average monthly rainfall is shown along the X-axis and the average monthly temperature along the Y-axis. From this point of view Taylor's Hythergraph is similar to Raga Lally Faster and Huntington's climograph. Taylor created the Hythergraph to explain the effects of climate differences in relation to human activity, especially settlements. It is used to study the climate of different regions and their different crops; For example, the effect on rice, wheat, cotton, tea, coffee, sugarcane, etc. is also compared.

Example: Draw hythergraph for Meerut with help of following data:

Month	Jan	Feb	Mar	Apr	May	Jun	Jul	Aug	Sep	Oct	Nov	Dec
Average Monthly Temperature(C)	14	16	22	28	31	32	30	29	27	24	18	14
	3	2	2	1	2	7	19	20	12	1	2	2

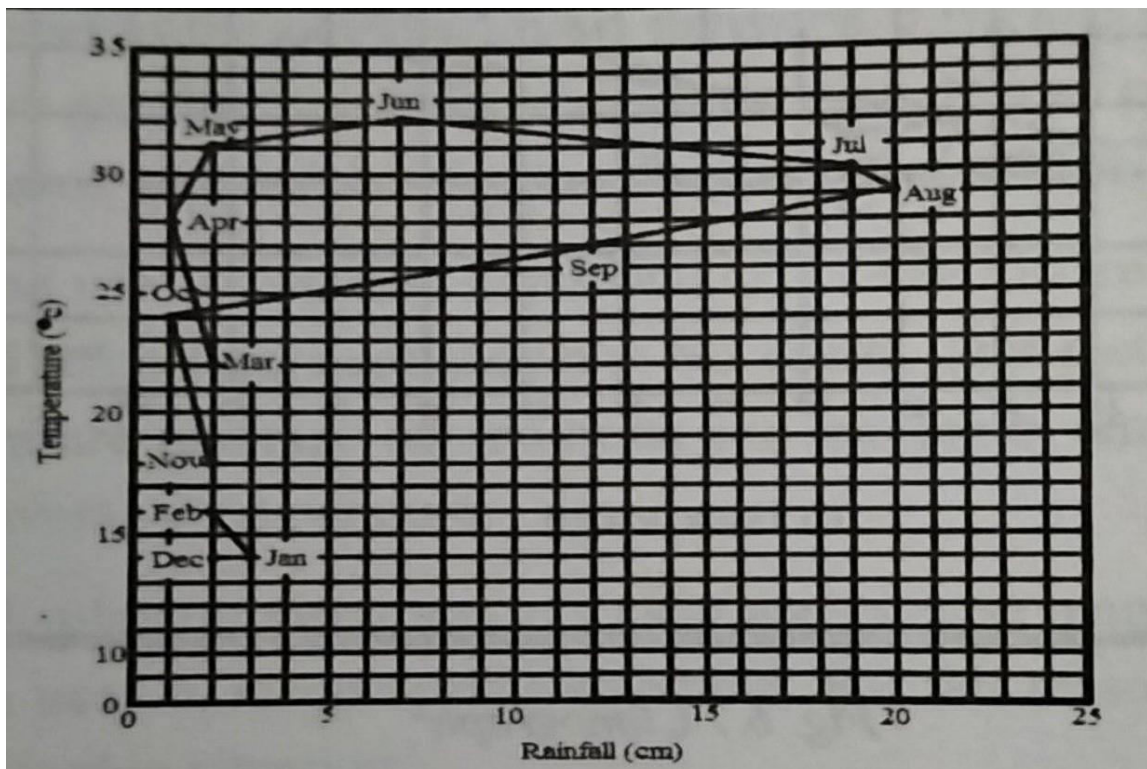

Fig.3.7 Hythergraph

Choose suitable scale to represent rainfall along the X- axis and temperature along the Y axis. Draw the coordinates of average monthly rainfall (3 cm) and average monthly temperature (14° C) to mark the point 'Jan' for January. Similarly, mark the remaining eleven points Feb., Mar., Apr etc. The twelve-sided figure so obtained is the hythergraph for meerut. Their major purpose is to provide general climate differences, which occur in different parts of the earth surface and effect human life in various ways. They are much superior to the other combined rainfall and

temperature graphs because they help a quick understanding of the relationship between varying atmospheric condition. Moreover, they are also well suited for comparative studies.

3.4 SUMMARY

Climate is defined as the average weather conditions at a specific location at a given time, as you studied in this course. The climate system, which consists of five components: atmosphere, hydrosphere, cryosphere, land surface, and biosphere, determines the climate of a region. Climate can include precipitation, temperature, humidity, sunshine, and wind velocity, as well as long-term events like fog, frost, and hail storms. Different instruments are used to measure various parameters. These instruments are used by weather stations to acquire meteorological data. Various tools and approaches can be used to analyze and plot these data. You have learned strategies that are highly important for representing major components of climate. As a result, some of the strategies contained in this section will assist you in better understanding the weather events that collectively represent climate. These are wind speed and direction, rainfall distribution at a specific location at a specific time, varying temperatures, their connection in a clear and succinct manner, and eventually how they affect each other and humans in various sections of the earth's surface. Thus, you should have seen by now that all of these methodologies play a significant role in comprehending meteorological and climatic components.

Before the advent of the compass rose, the wind rose, a graphic tool used by meteorologists, was incorporated on maps. The purpose of this diagram was to show the reader which directions the eight major winds blow within the plan view. The current wind rose diagram, which can provide more exact information, illustrates the frequency of winds flowing from various directions over a specific period. The length of each 'spoke' around the circle is proportional to the frequency of wind from a specific direction per unit time. Graphs are used in rainfall dispersion diagrams to highlight the main patterns in data distribution. Each value is shown as an independent point against a vertical scale in the graph. These diagrams, created using long-term meteorological data, forecast the maximum, minimum, median, lower quartile, and upper quartile. You will be able to determine the highest and least quantity of rainfall in each month after putting all of the

data in ascending order. After that, you'll be able to visualize your data using rainfall dispersion graphs.

A climograph represents at least two elements of climate (temperature and rainfall, temperature and humidity) at a given point of time in 1918, Kuipan constructed climographs with the help of highest and lowest recorded temperatures in the warm and cold months, providing a scientific foundation to the world climate division. Griffith Taylor invented the correlations between precipitation and temperature in the early twentieth century, as seen by this plotted graph. This form of graph is referred to as a Hythergraph. It is similar to Griffith Taylor's 1916 invention.

G. Taylor's Hythergraph is similar to the climograph as defined by Raize, Foster, and Huntington. The climographs and hythergraphs, on the other hand, both depict the link between rainfall and temperature. Furthermore, hythergraphs include wind speed and direction. They are ideal for comparative investigations.

Thus, in this unit, you learned to represent climate data, primarily temperature, rainfall, and wind direction, using various methods that are very important in studies related to climate differences that can be observed after careful observation of available data collected from various parts of the world. Furthermore, after studying this unit, you may be able to envision the changes that mankind will need to make to adapt to a world where shifting climate patterns are a major worry. All of the approaches presented in this section are designed to aid in the analysis and prediction of weather and climate variability and change for the use, benefit, and value of society.

3.5 GLOSSARY

The lower quartile: Is the median of the lower half of the geographical climate data set.

The upper quartile: The median of a data set's top half. This is found by dividing the data set with the median and then dividing the higher half that remains with the median again, the upper quartile being the median of the top half.

Land degradation: A process in which the value of the biophysical environment is influenced by a variety of human-caused processes that act on the land. It is defined as any modification or disturbance to the land that is either detrimental or unwanted.

Ice storms: A freezing rainstorm that leaves a layer of ice on the ground.

Greenhouse gases: Water vapour, carbon dioxide, methane, nitrous oxide, and ozone are the principal greenhouse gases in the earth's atmosphere.

Thunderstorms: A thunderstorm that includes thunder and lightning, as well as heavy rain or hail.

Blizzards: A severe snowstorm with sustained winds of at least 35 mph that lasts for an extended length of time--typically three hours or more.

Meteorology: The multidisciplinary scientific investigation of the atmosphere.

Biosphere: The biosphere is the biological component of earth systems that includes the lithosphere, hydrosphere, atmosphere, and other spheres. The biosphere contains all living species on Earth, as well as the dead organic stuff they produce.

Hydrosphere: The hydrosphere is the earth's liquid water component. The oceans, sea, lakes, ponds, rivers, and streams are all part of it. The hydrosphere spans over 70% of the Earth's surface.

Soil erosion: This is a natural process that occurs on every land. Water and wind are the agents of soil erosion, and each contributes a large quantity of soil loss each year.

Temperature: An impartial comparison of how hot or cold a quantity is.

Land degradation: A process in which the value of the biophysical environment is influenced by a combination of land-based human-induced processes. It is defined as any modification or disturbance to the land that is either detrimental or unwanted.

Scorching: high temperature (70°-80° F) and low relative humidity (below 40%)

Muggi: High temperature (70°-80° F) and high relative humidity (over 70%)

Keen: Low temperature (below 40° F) and low relative humidity (below 40%)

Raw: Low temperature (below 40%) and high relative humidity (over 70%) becomes thinner until it gradually reaches space. It is divided into five layers. Most of the weather and clouds are found in the first layer.

Atmosphere: The atmosphere is a mixture of nitrogen (70%), oxygen (21%), and other gases (1%), and it surrounds the world. Many plants and animals live in the atmosphere, which is located high above the globe.

Cryosphere: The cryosphere is the earth's frozen water system. North of Alaska, in the Beaufort Sea. Ice found in water is one component of the cryosphere. This includes frozen ocean areas such as those bordering Antarctica and the Arctic.

Frost: The formation of an ice coating or deposit in humid air during cold weather, usually overnight.

Humidity: The amount of water vapour in the atmosphere or a gas is represented by humidity.

Warm front: A transition zone in which a warm air mass replaces a cold air mass. Warm fronts migrate from southwest to northeast, and the air behind them is warmer and moister than the air ahead of them.

Cold front: A transition zone in which a chilly air mass replaces a warmer air mass. Cold fronts often move from the northwest to the southeast. The air ahead of a cold front is notably colder and drier than the air behind it.

Predecessors: A thing that has been followed or replaced by another.

3.6 ANSWER TO CHECK YOUR PROGRESS

(Self-check Questions)

1. Who scientifically divisions climographs to divide the planet into climate zones?
2. How do you search for patterns, correlations, and sequences in accessible climatic data?
3. Where are wind roses utilized as a preliminary step in modern times?
4. Who was the creator of the hythergraph?

5. How can the climate of a specific location be accurately understood?
6. Define 'weather'.
7. What exactly is a wind rose diagram?
8. What does each "spoke" in the wind rose graphic mean?
9. What exactly is climate?
10. What are the drawbacks of climographs?
- 11 How do you represent climatic data?
12. Fill in the blanks with the appropriate words from the list below (orders, ascending, plotted, visual tool).
 - A. The temperature is..... along the vertical coordinate.
 - B. A wind rose is a..... employed mostly by meteorologists.
 - C. Taylor's climograph denotes wet bulb temperatures as..... and relative humidity as abscissae.
 - D. In the rainfall dispersion graphs, you must first arrange all of the data in..... order.

(Answers to self-check Questions)

1. In 1918, Kuipan built climographs, providing a scientific foundation for the world's climatic divisions. The highest and lowest recorded temperatures in the warm and cold months were used in his division.
2. Using simple statistical approaches, you can discover patterns, connections, and sequences in accessible climate data.
3. Wind collection as aircrafts often execute their greatest take-off and landing sites into the wind, rise is one of the earliest measures taken in the construction of airport runways.
4. Griffith Taylor devised the hypthergraph in 1916.
5. The climatic conditions of the entire planet, or of a specific area or region within it, can be understood through the gathering, analysis, and representation of weather data for that specific place or region.
6. Weather refers to the atmospheric conditions at a certain location at a specific moment.

7. A wind rose diagram depicts the frequency of winds flowing from certain directions over a specific time period.
8. The length of each "spoke" in the wind rose diagram indicates the frequency of wind arriving from a specific direction.
9. Climate is detailed statistical weather information that describes the variance of weather at a certain location throughout time.
10. Although climographs represent temperatures in a clear and succinct manner, misinterpretation is possible if not used in proper settings. As a result, they must be able to be employed in a legitimate setting.
11. Climatic data can be represented using several types of graphs and diagrams.

12. Fill in the blanks with the appropriate words given below

- A. Temperature is **plotted** along the vertical coordinate.
- B. Wind rose is a **graphic** tool used basically by meteorologists
- C. Taylor's climograph represents wet-bulb temperatures as **ordinates** and relative humidity as abscissae.
- D. In the rainfall dispersion diagrams, first you will have to arrange all the data in **ascending** order.

3.7 REFERENCES

1. Kleindienst, S., Bodart, M. Anderson, M (2008) Graphical representation of climate based daylight performance to support architectural design.
2. Robinson, A. H., (1982). Early Thematic Mapping: In the History of Cartography Chicago: The University of Chicago Press. ISBN 0-226-72285-6
3. Barnaby, C. (2011): Weather data for building performance simulation, pp: 37-55.
4. Birch, T.W.: Topographical & Statistics Maps, Clarndon Press, Oxford. Barnaby, C (2011). Weather data for building performance simulation, pp: 37-55.
5. Dickinson, G. C., (1963), Statistical mapping and the presentation of Statistical data, London.
6. Garnett, A: Geographical Interpretation of Topographical Maps George Hamp & Co. London
7. Bankks, James A. (1997). United States: Adventure in time and place. Macmillan. P. 242.
8. Singh, R.L. and Dutt, P.K.: Elements of practical Geography, Students Friends, Allahabad.

9. Hensen, J. L. M., (1999). Simulation of building energy and indoor environment quality-some weather data issues, Proceedings of the International Workshop on climate data and their applications in engineering, pp. 1-15.
10. Bygott, J., (1948): An Introduction to Map work and Practical Geography, London
11. Mahmood, A., (1977): Statistical Methods in Geographical Studies, Rajesh Publications, New Delhi.
12. Mishra, R. P. and Ramesh, A.: Fundamental of Cartography, Macmillan, New Del 1986
13. Singh, S, P. Singh, V. and Margaret, S., Rapid warming in the Himalayas: Ecosystem responses and development options, Climate and development, 2010, 2, 1-13.
14. Monkhouse, F. G. and Wilkinsion, H. R., (1956): Maps and Diagrams, Methuen London.
15. Singh, L. R. and Singh, R. L., (1991): Map work and Practical geography, Indi University Press, Allahabad. pp 165-203.
16. Singh. R. L, Elements of Practical Geography, Kalyani publishers, New Delhi.
17. Sharma. J.P. Practical Geography, Rastogi Publishers, Meerut.
18. Misra, R. P. and Ramesh, A., (1969): Fundamentals of Cartography, Concept Publications, New Delhi.
19. Mishr, P., L., (2010) Practical Geography vishwbharti publications, New Delhi.
20. Khullar, D., R., Tata McGraw-Hill's, Published by the Tata McGraw Hill Education Pvt. Ltd.7. West Patel Nagar, New Delhi 110008.
21. <https://www.google.co.in>
22. <https://sites.google.com/site/skillsa229/dispersion>
23. <https://en.wikipedia.org/wiki/Wind-rose#cite-note-3>
24. <http://www.cotf.edu/ete/modules/mesese/earthsys/flr/climograph.html>.
25. <http://www.yourdictionary.com/hythergraph>.
26. https://en.wikipedia.org/wiki/Wind_rose#history.
27. <http://www.mtavalanche.com/weather/windrose>.

3.8 TERMINAL QUESTIONS

1. What is the connection between weather and climate?
2. Who was the creator of the hythergraph?

3. How do you search for patterns, correlations, and sequences in the given climatic data?
4. Describe the modifications in the modified form of climographs following Griffith Taylor.
5. What is the first step towards understanding a popular region's climate?
6. Who employed scientific climographs to divide the planet into climate zones?
7. How can climatic data be represented?
8. Highlight the primary variables that influence the state and condition of the environment.
9. Why is weather data representation included in geographical studies?
10. Discuss meteorology. What is the significance of meteorological data for geography students?

UNIT-4 CARTOGRAPHIC REPRESENTATION OF SOCIO-ECONOMIC DATA

4.1 INTRODUCTION

4.2 OBJECTIVES

4.3 CARTOGRAPHIC REPRESENTATION OF SOCIO-ECONOMIC DATA

4.3.1 DOT MAP

4.3.2 PROPORTIONAL SQUARES

4.3.3 CIRCLES

4.3.4 SPHERES

4.3.5 CHOROPLETH MAP

4.3.6 STAR AND SCATTER DIAGRAMS

4.3.7 ERGOGRAPHS

4.3.8 FLOW LINE DIAGRAMS

4.3.9 IN TEXT QUESTIONS

4.4 SUMMARY

4.5 GLOSSARY

4.6 ANSWERS TO INTEXT QUESTIONS

4.7 REFERENCES

4.8 TERMINAL QUESTIONS

4.1 OBJECTIVES

After having the detailed study of this unit you will be able to

- Know cartographic representation is different for various socio-economic data.
- Know their advantages, disadvantages, and steps to construct them.
- Identify and represent data through appropriate diagrams.

4.2 INTRODUCTION

This unit will study the representation of various socio-economic and climatic data such as dot map, Star and scatter diagram, Ergograph, Choropleth, Flowline diagrams, Circles, and proportional spheres. We will also study the concept behind these and their advantages, disadvantages, steps involved, and construction of these diagrams. In this unit, we will also try to explain the various methods of representation of geographical data.

4.3 CARTOGRAPHIC REPRESENTATION OF SOCIO-ECONOMIC DATA

The socio-economic data includes vast information on literacy and education, the standard of living and poverty, urbanization and related phenomenon, health and disease, labour force and employment, the status of women and gender empowerment, population parameters relevant to fertility, mortality and migration, ecology, and environmental protection. This data is used in geographical space and needs to be scientifically visualized through cartographic techniques. The technique is usually based on the objective of the data and also the available data. In this section, several cartographic techniques have been discussed.

4.3.1 DOT MAP

Dot mapping is a method of cartographic representation to visualize discrete absolute values and their distribution over geographical space. Here uniform-sized dots are plotted to represent the distribution of socio-economic data like population figures. According to the dot value, a certain number of dots are used to depict the value of the data. It is a highly effective method to show density across a geographical area. Thus these dots usually form dot clusters.

This method is widely used to indicate the population distribution of any region or country. Too many dots give an insight of high density, whereas fewer or lesser dots show sparse distribution. Dot maps must be prepared on an equal-area map projection. To show patterns of distribution, dots of the same value are marked on the administrative map.

While making a dot map, the main problem is selecting a suitable size and value of the dot. Placing the dots on a map is also a difficult task. Therefore, the dot representation should be combined with other elements like topography. A dot or any symbol can be mapped in the known location in dot maps to show the distribution. Thus it is the visual representation to show raw data which follow these basic principles –

- a. Dot sizes are subjectively scaled
- b. Dots are positioned and centered precisely at the map location.
- c. The advantages of this technique are –
 - a. It is easy to understand
 - b. It is an appropriate method to show the distribution of population across space
 - c. By counting the dots or symbols, it is possible to determine the total values.

And, the disadvantages are -

- a. It is difficult to count and place a large number of dots to get a precise value.
- b. Knowledge about the physiographic before placing the dots is essential.
- c. It is time-consuming work.
- d. One needs to have a large amount of initial information before drawing the map.

Requirement

- a. Take an administrative map of the chosen area.
- b. Collect all the data required for the chosen area, i.e., total population, etc.
- c. Select a particular scale to map the dots of the same value.
- d. Dots must be of the same size.

Example: Construct a dot map to represent the distribution of rural population in various districts of Punjab based on the following data.

Districts	Rural Population
Gurdaspur	1643882

Firozpur	1474592
Ludhiana	1425201
Hoshiarpur	1247969
Amritsar	1154831
Sangrur	1137633
Patiala	1130279
Jalandhar	1021388
Tarn Taran	978611
Bathinda	888943
Moga	768499
Muktsar	650004
Mansa	605356
Kapurthala	532296
Rupnagar	505529
SBS Nagar	488857
SAS Nagar	442112
Fatehgarh Sahib	414649
Barnala	405675
Faridkot	400494

Rural Population of Districts of Punjab – 2011

Construction

- Select the appropriate size and value of a dot.
- Choose a number of dots to be represented using the given scale. For example, the number of dots in SAS Nagar will be $442112/1,00,000 = 4.42$, which can be rounded to 4.

Districts	Rural Population	Number of Dots (1 dot = 1,00,000)
Gurdaspur	1643882	16.43 = 16
Firozpur	1474592	14.74 = 15
Ludhiana	1425201	14.25 = 14
Hoshiarpur	1247969	12.47 = 12

Amritsar	1154831	11.54 = 12
Sangrur	1137633	11.37 = 11
Patiala	1130279	11.30 = 11
Jalandhar	1021388	10.21 = 10
Tarn Taran	978611	9.78 = 10
Bathinda	888943	8.88 = 9
Moga	768499	7.68 = 8
Muktsar	650004	6.50 = 7
Mansa	605356	6.05 = 6
Kapurthala	532296	5.32 = 5
Rupnagar	505529	5.06 = 5
SBS Nagar	488857	4.89 = 5
SAS Nagar	442112	4.42 = 4
Fatehgarh Sahib	414649	4.14 = 4
Barnala	405675	4.06 = 4
Faridkot	400494	4.00 = 4

- a. Place the dots in respective areal units as per the determined number in each district.
- b. Place dots according to the physical features of Punjab, such as a river, mountains, plains, deserts, etc., to mark fewer dots in such areas.

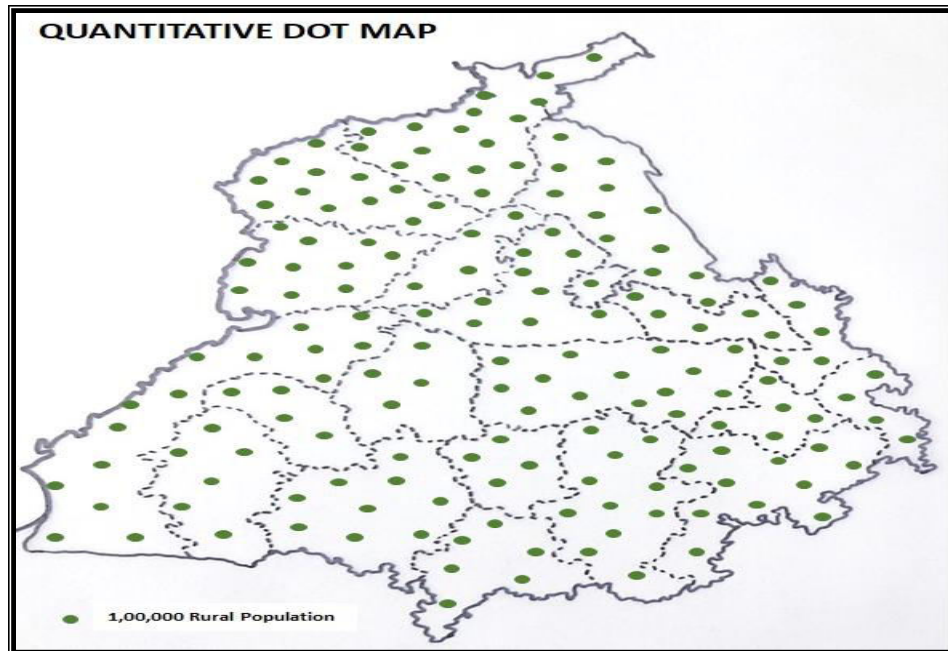

Fig. 4.1 Dot Method representing Rural Population of Districts of Punjab-2011

4.3.2 PROPORTIONAL SQUARES

A proportional square is a cartogram that compares proportions (size, quantities, etc.) to provide a quick overview of the relative size of data without scales. These are two-dimensional diagrams consisting of a series of squares proportional to the quantities they represent. There are two methods of construction of proportional squares based on the availability of data. These are –

- i. Simple square diagram: Where data for only one component is available, each square represents that single value.
- ii. Compound square diagram: this helps in comparing more than one component through various segments.

The basic principle in the construction of these diagrams is that the area of the square (a) is directly proportional to the area to be represented.

The advantages of this technique are –

- a. Easy to construct
- b. It displays relative proportions of data
- c. It summarizes a large set of data visually.
- d. Simpler than other graphs visually

e. It can accommodate several figures and can be used together with other diagrams such as maps

f. Involve few calculations

And, the disadvantages are -

a. It does not show the precise value.

b. It can be easily manipulated.

c. Are sometimes difficult to interpret because of over-lapping

d. They occupy considerable space, hence are less economical

Requirement

a. Take an administrative map of the chosen area as in example 1 or on a plain sheet of paper as in example 2.

b. Collect all the data required for the chosen area, i.e., total population, etc.

c. Select a particular scale to draw the squares, be it simple or compound, as shown in the example cited below.

Example 1: Construct proportional squares (simple) according to the data provided below.

Districts	Total Area (in Sq.kms)
Darjeeling	3149
Jalpaiguri	6227
Cooch Behar	3387
Uttar Dinajpur	3140
Dakshin Dinajpur	2219
Maldah	3933

Area of the Districts of North Bengal – 2011

Construction:

As shown in the table provided below:

Districts	Total area (in sq. km)	Length of the side ($L=\sqrt{\text{Area}}$)	Length of the side according to the scale (1 cm = 40 units)

Darjeeling	3149	56.1	1.4
Jalpaiguri	6227	78.9	1.9
Cooch Behar	3387	58.2	1.5
Uttar Dinajpur	3140	56.0	1.4
Dakshin Dinajpur	2219	47.1	1.1
Maldah	3933	62.7	1.6

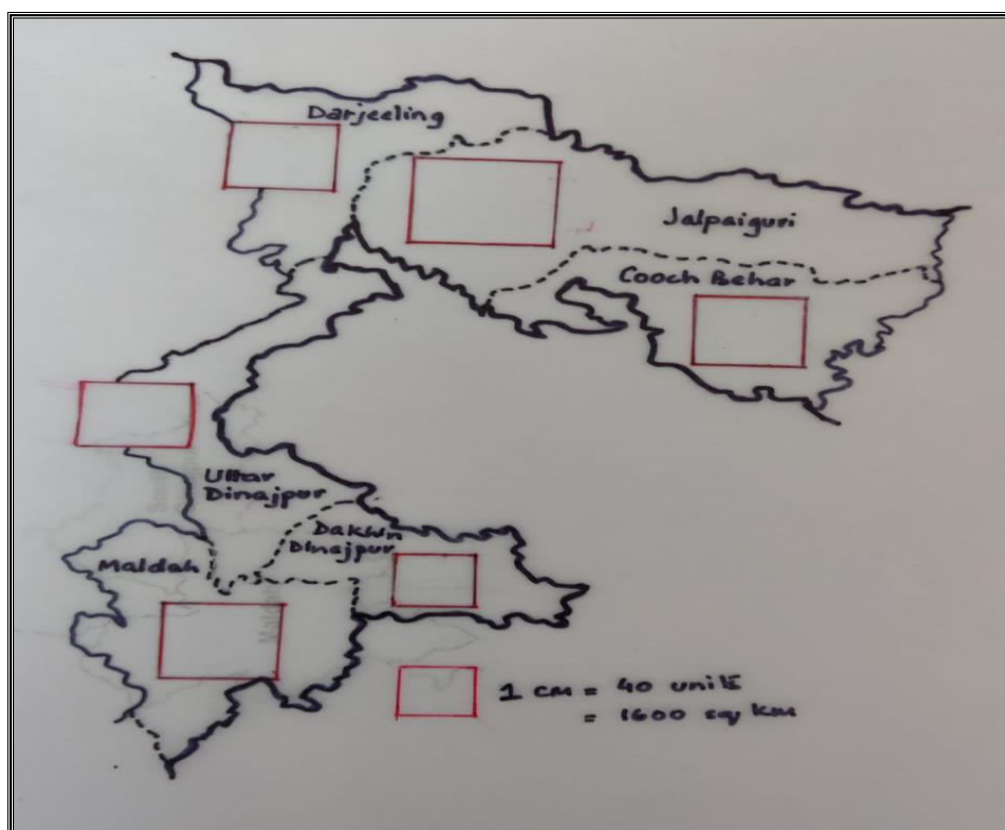

Fig. 4.2 Simple Proportional Squares representing Area of Districts of North Bengal – 2011

Example 2: Construct proportional squares (compound) according to the data provided below.

Segments	Total Population	Literate Population
X 1	14589	11540
X 2	15987	9876

X 3	19580	18855
X 4	20012	19790
X 5	22115	20014

Total and Literate population in X Area

Construction:

As shown in the table provided below:

Segments	Total Population	Length of the side (L= $\sqrt{\text{Area}}$)	Length of the side according to the scale (1 cm=100 units)	Literate Population	Length of the side (L= $\sqrt{\text{Area}}$)	Length of the side according to the scale (1 cm=100 units)
X 1	14589	120.8	1.2	11540	107.4	1.1
X 2	15987	126.4	1.3	9876	99.4	0.9
X 3	19580	139.9	1.4	15855	125.9	1.3
X 4	20012	141.5	1.4	16790	129.6	1.3
X 5	22115	148.7	1.5	20014	141.5	1.4

Compound Proportional Squares showing total and literate population in X area

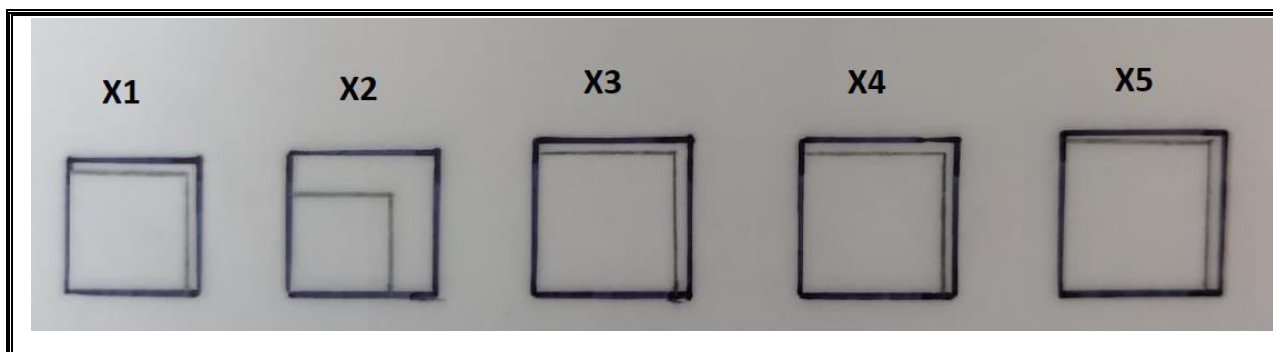

Fig. 4.3

4.3.3 CIRCLES

A circle cartogram is a type of area cartogram on which circles represent the distribution of the urban population, particularly on a regional scale. In such a composite map, the size of the dot is commensurate with the size of the circle. For example, if a dot with a diameter of 0.5 cm

represents two crore persons (as in Figure 3), then a 1 cm diameter will represent four crore persons. Thus as the population increases, the circles representing them also correspondingly become bigger. In simpler words, the values of the data are realized by the size of the circle- the bigger the circle, the more significant the data value. These cartograms are also known as Dorling cartograms after their creator Danny Dorling.

The advantages of this cartogram are –

- a. It expresses a spatial distribution of data.
- b. It avoids the overlap of circles.
- c. It keeps the contiguity of regions as much as possible.
- d. It keeps the similarity of configuration between circles and regions on the geographical maps.
- e. They are widely used.

The disadvantages are –

- a. The relative positions of the circles sometimes significantly differ from the exact location on the geographical maps.
- b. The displacement of circles creates confusion in distinguishing which circle represents which particular region.

Construction:

Construct Dorling cartograms according to the data provided below.

States	Total Population
Uttar Pradesh	199,812,341
Tamil Nadu	72,147,030
Rajasthan	68,548,437
Haryana	25,351,462
Delhi	16,787,941

- a. Convert the given data into round figures and arrange them in descending order.
- b. Select a suitable scale, keeping in mind the size of the paper and the given data.
- c. Suppose a circle 1 cm radius represents a population of 2.5 crores.

d. Calculate the radius of the circle representing the state with the largest population, i.e., Uttar Pradesh

$$=1.0\text{cm} \times \sqrt{24.28/2.5}=3.11$$

Name of the State	Population (Actual)	Population in round figures (in Crores)	Length of the radius of the concerned circle (in centimetre)
Uttar Pradesh	1,99,812,341	19.98	$=1.0 \sqrt{19.98/2.5}= 1.78$
Tamil Nadu	72,147,030	7.21	$=1.0 \sqrt{7.21/2.5}=1.07$
Rajasthan	68,548,437	6.85	$=1.0 \sqrt{6.85/2.5}=1.04$
Haryana	25,351,462	2.53	$=1.0 \sqrt{2.53/2.5}=0.63$
Delhi	16,787,941	1.67	$=1.0 \sqrt{1.67/2.5}=0.51$

Steps:

- Draw five circles with radii as calculated in the above table and write the names of the respective states.
- The circles must be drawn that their centers lie on a straight line and are placed at equal distance.
- Draw another circle to show the scale.

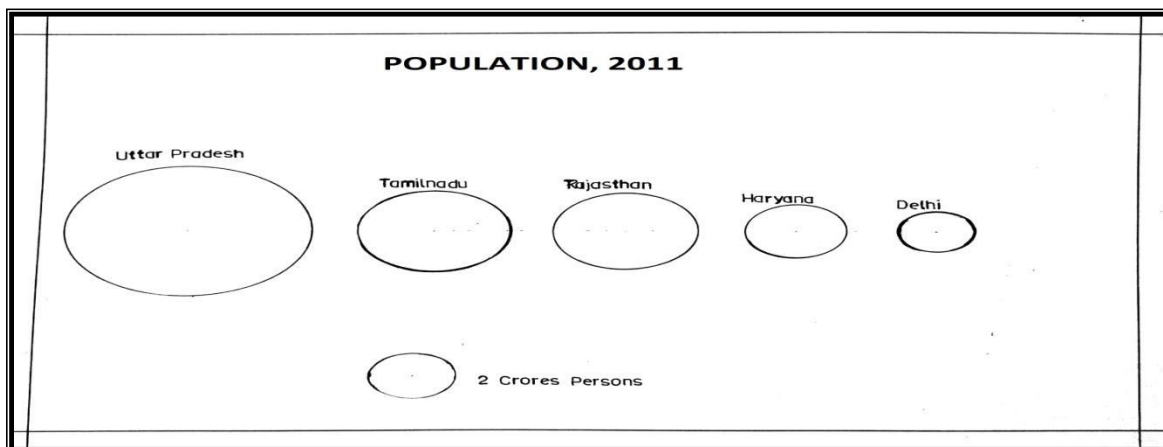

Fig. 4.4 Circles showing the total population of selected Indian States – 2011

Another type of circle that is commonly used is known as a proportional circle. These represent data of a specific geographical point. In such maps, a symbol is used to describe the data and then scaled by value so that a larger symbol represents a greater value. Thus, the size of each sign can be proportional to the value one is visualizing, and one can set 3 to 5 classes of values allowing for comparison and classification of locations.

The advantages of this technique are –

- a. Proportional Symbol maps are not dependent on the size of the area associated with the variable, so all areas have equal visual importance.
- b. It provides a quick visual comparison in a spatial context – i.e., differences between places.
- c. It displays relative proportions of multiple classes of data.
- d. It summarizes an extensive data set in visual form.
- e. It is visually simpler than other types of graphs.
- f. Permits a visual check of the reasonableness or accuracy of calculations
- g. Requires minimal additional explanation

The disadvantages of this technique are –

- a. If a substantial amount of data and subtle variations, it can be challenging to provide a visually meaningful comparison
- b. It does not readily reveal exact values.
- c. It fails to reveal key assumptions, causes, effects, or patterns.
- d. It can be easily manipulated to yield false impressions.

Construction:

Construct proportional circles according to the data provided below.

Urban Settlements	Population
Almora	34122
Chamoli	391605
Dehradun	578420
Haldwani	140884
Hardwar	225235

Joshimath	15093
Kashipur	56044
Pauri	25440
Pithoragarh	41377
Rudrapur	121610
Tehri Garhwal	24014
Uttarkashi	17475

Population of Urban Settlements of Uttarakhand – 2011

Steps:

1. Arrange the data in ascending or descending order.
2. Classify the data into 3 or 5 classes (in this case, five classes):
 - i. Above 5 lakhs - I
 - ii. 2,00,000 – 4,99,999 - II
 - iii. 50,000 - 1,99,999 - III
 - iv. 20,000 – 49,999 - IV
 - v. Less than 19,999 – V

Urban Settlements	Population	Classes
Dehradun	578420	I
Chamoli	391605	II
Hardwar	225235	II
Haldwani	140884	III
Rudrapur	121610	III
Kashipur	56044	III
Pithoragarh	41377	IV
Almora	34122	IV
Pauri	25440	IV
Tehri Garhwal	24014	IV
Uttarkashi	17475	V
Joshimath	15093	V

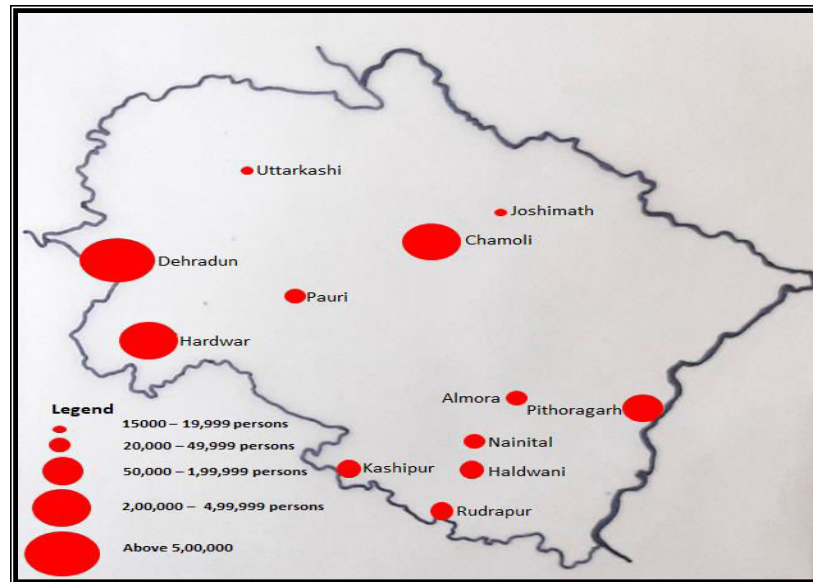

Fig. 4.5 Proportional Circles showing the Population of Urban Settlements of Uttarakhand – 2011

3.3.4 SPHERES

A sphere is generally used to represent the urban population at one go. They typically represent volume expressly when the data is disproportionately large and cannot be adequately represented using a two-dimensional diagram. Sphere thus is a 3-dimensional diagram used to represent the urban population as a substantial population is concentrated in a very small areal unit, i.e., a town or city represented often by a singular marker on a map.

The advantages of spheres are -

- Easy to construct.
- They promote an excellent visual impression.
- They can accommodate several figures.
- They can be used together with other diagrams such as maps.
- They involve few calculations.

While the disadvantages are -

- They are sometimes tricky in interpretation due to over-lapping.
- It is hard to analyze small figures reflected between totals.
- It shows the statistics on the spheres directly; if a slight difference exists
- between figures, it is hard to tell the accuracy of the statistics.
- They occupy considerable space, hence are less economical.

Construction:

Construct spheres according to the data provided below.

Sl. No.	Metropolitan City	Total Population
1	Mumbai	12, 442,373
2	Delhi	11, 034, 666
3	Bengaluru	8, 499, 399
4	Hyderabad	6, 731, 790
5	Ahmedabad	5, 577, 940

Calculation of radius of a sphere to represent the urban population

The formula for volume of sphere= $\frac{4}{3}(\pi r^3)$

$$\frac{4}{3}(\pi r^3) = \text{volume of Sphere}$$

$$\text{or } \frac{4}{3}(\pi r^3) = \text{urban population}$$

$$\text{or } \pi r^3 = \frac{3}{4} \times \text{urban population}$$

$$\text{or } r = \sqrt[3]{\frac{3 \times \text{U.P}}{4\pi}}$$

where U.P = urban population(in given sum)

The radii for the given data is calculated as shown in the table below:

Metropolitan City	Total Population	Radii of Sphere $r = \sqrt[3]{\frac{3 \times \text{U.P}}{4\pi}}$	Radii to scale 1cm=3000 units
Mumbai	12, 442,373	6999	2.3
Delhi	11, 034, 666	6591	2.1
Bengaluru	8, 499, 399	5785	1.9
Hyderabad	6, 731, 790	5148	1.7
Ahmedabad	5, 577, 940	4686	1.6

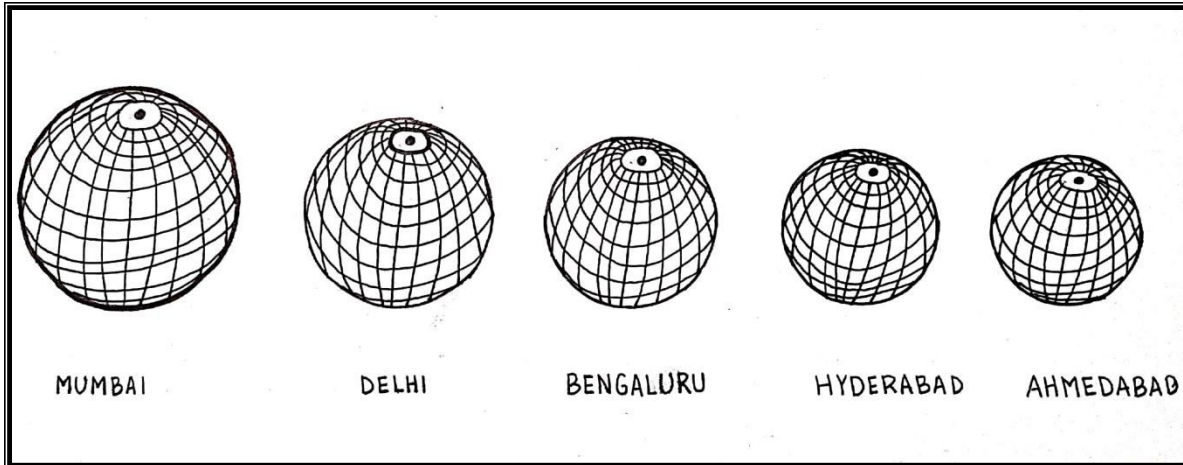

Fig. 4.6 Spheres showing Population of Major Cities of India-2011

3.3.5 CHOROPLETH MAP

Choropleth Maps are drawn to show the characteristics of data as they are related to the administrative units. Choropleth is derived from two terms, 'Choros' meaning area and 'Pleth' meaning value. Thus, Choropleth is mapping the techniques to symbolize values applied to the area. These maps help to map land-use patterns or types of forest cover. Choropleth maps show the density, literacy, sex ratio, etc. Different interval data are shown through different colour sets. The lighter colour shows low values, whereas the darker colour represents higher values, using single colour shades. Each colour types show a range of values. Choropleth maps are easy to understand and are widely used thematic maps.

The advantages of Choropleth Maps are –

- a. Give a good visual impression of the data and changes over space
- b. The patterns can easily be identified.
- c. Easy to complete

While the disadvantages are -

- a. It becomes difficult to understand the different colour shades of the values.
- b. These maps are inappropriate to show total values.
- c. They show abrupt changes at the boundaries of different colour shaded units
- d. hides variations within an area
- e. choropleth maps also suggest that there are sharp contrasts between areas where the boundaries of the maps are drawn (again – not reflective of reality).

f. If too many categories, it can be difficult to distinguish between shades.

g. Only show the spread of data and not actual amounts.

Construction

Draw a choropleth map based on the data provided below.

States/Union Territories	Population Density - 2011	States/Union Territories	Population Density - 2011
Andaman and Nicobar Islands	46	Lakshadweep	2149
Andhra Pradesh	308	Madhya Pradesh	236
Arunachal Pradesh	17	Maharashtra	365
Assam	398	Manipur	115
Bihar	1106	Meghalaya	132
Chandigarh	9258	Mizoram	52
Chhattisgarh	189	Nagaland	119
Dadra and Nagar Haveli	700	Odisha	270
Daman and Diu	2191	Puducherry	2547
NCT of Delhi	11320	Punjab	551
Goa	394	Rajasthan	200
Gujarat	308	Sikkim	86
Haryana	573	Tamil Nadu	555
Himachal Pradesh	123	Tripura	350
Jammu and Kashmir	124	Uttar Pradesh	829
Jharkhand	414	Uttarakhand	189
Karnataka	319	West Bengal	1028
Kerala	860	Tripura	350

Steps

1. Arrange the data in ascending or descending order.

States/Union Territories	Population Density -2011
Arunachal Pradesh	17
Andaman and Nicobar Islands	46
Mizoram	52
Sikkim	86
Manipur	115
Nagaland	119
Himachal Pradesh	123
Jammu and Kashmir	124
Meghalaya	132
Chhattisgarh	189
Uttarakhand	189
Rajasthan	200
Madhya Pradesh	236
Odisha	270
Andhra Pradesh	308
Gujarat	308
Karnataka	319
Tripura	350
Maharashtra	365
Goa	394
Assam	398
Jharkhand	414
Punjab	551
Tamil Nadu	555
Haryana	573
Dadra and Nagar Haveli	700

Uttar Pradesh	829
Kerala	860
West Bengal	1028
Bihar	1106
Lakshadweep	2149
Daman and Diu	2191
Puducherry	2547
Chandigarh	9258
NCT of Delhi	11320

2. Group the data into five categories to represent very high, high, medium, low, and very low concentrations.

3. The interval between the categories may be identified on the following formulae, i.e., $\text{Range}/5$ (Range = maximum value – minimum value).

Below 100	Arunachal Pradesh, Andaman & Nicobar, Mizoram, Sikkim
101-200	Nagaland, Manipur, Himachal Pradesh, Jammu & Kashmir, Meghalaya, Chhattisgarh, Uttarakhand, Rajasthan, Madhya Pradesh
201-500	Orissa, Gujarat, Andhra Pradesh, Karnataka, Tripura, Maharashtra, Goa, Assam, Jharkhand
501-1000	Punjab, Tamil Nadu, Haryana, Dadra & Nagar Haveli, Uttar Pradesh, Kerala
Above 1001	West Bengal, Bihar, Lakshadweep, Daman & Diu, Puducherry, Chandigarh, Delhi

4. We will finally get the classes, as shown in the table below.

5. Patterns, shades, or colours to depict the chosen categories should be marked in an increasing or decreasing order.

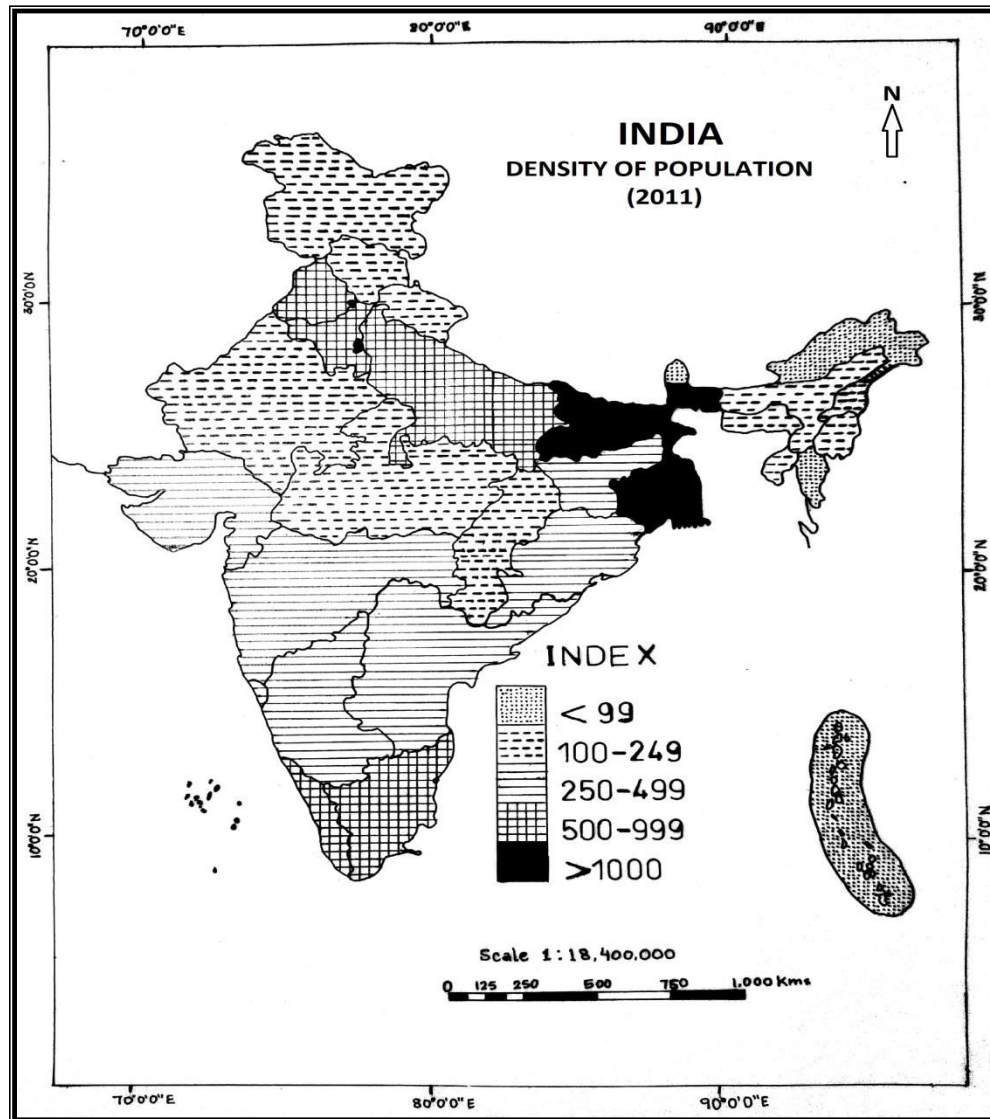

Fig. 4.7 Choropleth Map showing Density of Population of States of India-2011

4.3.6 STAR AND SCATTER DIAGRAM

The most common star diagram is a wind rose diagram. This diagram is known as a star diagram as it looks like a star in which the light emanates from the center to all the directions. As you know, there are sixteen directions – four cardinal or primary directions and twelve secondary directions. Therefore, in the wind rose, a maximum of sixteen lines can be drawn from the center representing the corresponding sixteen directions (see Fig. 8). The length of each line would be

proportionate to the quantity it means. So, each ray will represent the number of hours or days the wind blows from the corresponding direction in a particular period. But there are some hours or days (as the case may be) when the wind is calm. These calm periods are generally shown by drawing a small circle at the center and writing the number within the circle. After all the lines are drawn, the endpoints of all the lines are joined.

Construction

Draw a star diagram for the data given below for Panjim.

Panjim										
Direction of the Wind	N	NE	E	SE	S	SW	W	NW	CALM	Total
No. of Days	21.9	83.95	102.2	21.9	7.3	21.9	36.5	21.9	47.45	365
No. of Days (rounded fig)	22	84	102	22	7	22	37	22	47	365
% No. of Days	6	23	28	6	2	6	10	6	13	100

Steps:

1. Select a suitable scale (here, 1 cm = 10 per cent)
2. Draw a circle to represent the calm for this scale.
3. Mark the directions in this circle using a protractor, as shown in the figure. (considering 0° for north, 45° for NE, 90° for East, 135° for Southeast, 180° for South, 225° for Southwest, 270° for West and 315° for Northwest).
4. Draw a bar suitable with equal to the length of 2.2 cm in the northern direction, 8.4 cm in the north-eastern direction, and so on to complete the diagram.
5. Mention the calm in the centre, mention the scale chosen to draw the diagram, and name the directions as instructed above.

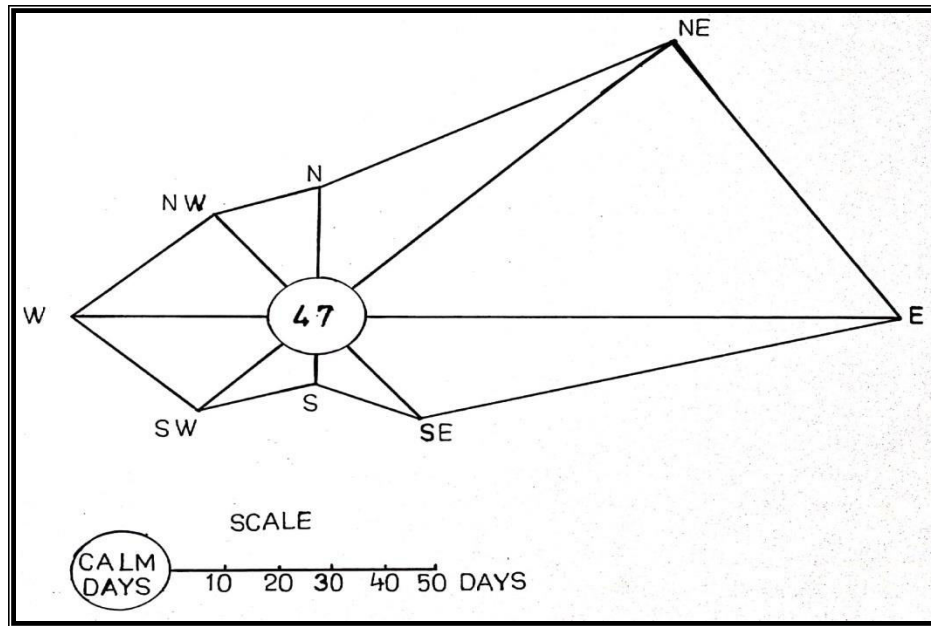

Fig. 4.8 Wind Rose Diagram or Star Diagram of Panjim

Scatter Diagrams: These are used to investigate the relationship between two variables. For example, the number of services in a settlement compared to the settlement population. The pattern of the scatter describes the relationship. A line of 'best-fit' can be drawn where there is an obvious relationship between the variables.

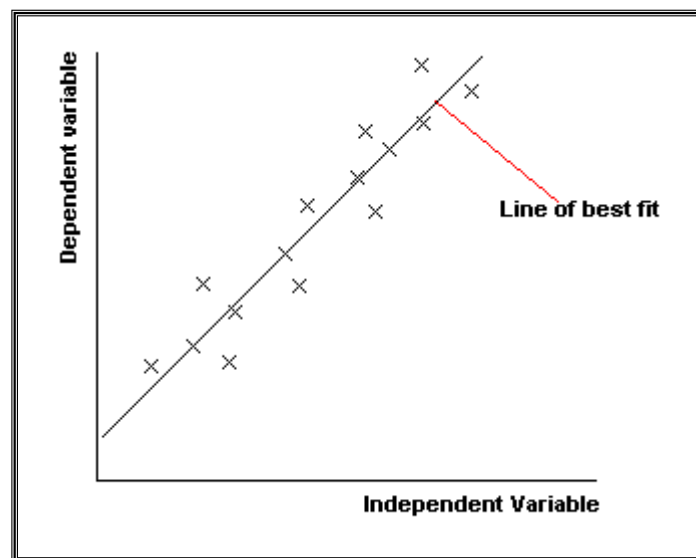

Fig. 4.9 Scatter Diagram

The advantages of scatter diagrams are:

- a. Overall impression of the data
- b. Show potential trends and correlations in the data

- c. Shows relationship between 2 variables
- d. It can be used to identify the nature of any relationship that exists and indicate its strength.

While the disadvantages are:

- a. No causal link
- b. data on both axes must be continuous –
- c. While a line of the best-fit line can suggest a relationship, a statistical test will be required to test for the significance of the relationship

Construction

Create a scatter diagram from the following data.

Months	Number of Buses from destination 1 to destination 2	Number of Accidents
September	30	5
August	35	15
July	40	20
June	35	25
May	30	35
April	25	20
March	20	15
February	15	10
January	10	5

Steps:

1. Decide which variable is an independent variable (affects the other one) and the dependent one (here, the number of buses will be independent).
2. The independent one will be on the x-axis and the dependent one along the y-axis.
3. Based on the data values, select the scale and plot the data on the x and y axes.
4. Draw a line of best-fit and identify the relationship between the two variables.

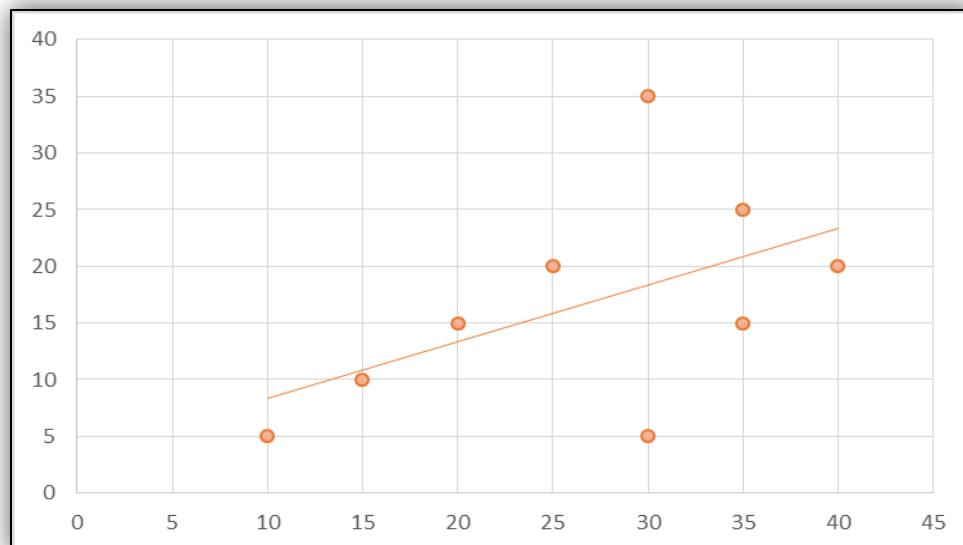

Fig. 4.10 Scatter Diagram showing the relationship between the numbers of buses and accidents that occurred in various months at X station

4.3.7 ERGOGRAPHS

Ergographs are graph that shows the relation between the season, climate and crops. The term ergo means work derived from the Greek word *erogon*. The name Ergograph was coined by Dr. Arthur Geddes of the University of Edinburgh.

Ergograph is a graph with multiple variables showing economic activities performed in a particular season. The relation between human activities or climatic factors and a seasonal year can be shown graphically by Ergographs. It can be shown on the bar graph or line graph. In cartesian form, months are marked on the horizontal axis with the acreage of different crops, and the vertical axis shows the monthly average temperature, rainfall, and humidity. Temperature, precipitation, and humidity are chosen as they have a direct impact on crop production. The rectangular blocks show the net acreage of the crops, where the length of the block shows a growing season, and its breadth is calculated to a selected scale.

In Ergograph, three elements are shown differently. First, the cultivated area will be demonstrated through the rectangular diagram. Second, rainfall can be shown through a bar graph, whereas line graphs can show temperature or humidity.

Construction

Construct an Ergograph of Station A representing the data given below:

Months	Jan	Feb	Mar	Apr	May	Jun	Jul	Aug	Sep	Oct	Nov	Dec
Temperature (degree Celsius)	13	15	22	27	30	31	30	29	28	27	18	15
Rainfall (mm)	29	28	9	11	14	60	299	298	290	15	7	9

Crops	Growing Season	Net Sown Area (in '00 Hectares)
Rice	May to October	28.4
Wheat	November to April	50.6
Cotton	June to December	13.4
Sugarcane	May to December	2.2

Net acreage of various crops along with their growing season:

Steps:

1. On x-axis represent 12 months of the year
2. On the y-axis, the rainfall and temperature are represented.
3. A suitable scale is selected to represent these two factors. Here, the scale used for temperature is 1 cm = 5 degrees Celsius and for rainfall is 1 cm = 30 mm.
4. Temperature is shown through a line graph and rainfall through continuous bars.
5. The net sown area is shown through rectangles at the lower end of the graph. Again, a scale is fixed; here, the scale used is 1 cm = 200 hectares. The rectangle should be of the proportionate width and cover the months of the growing season, as shown in figure 11.

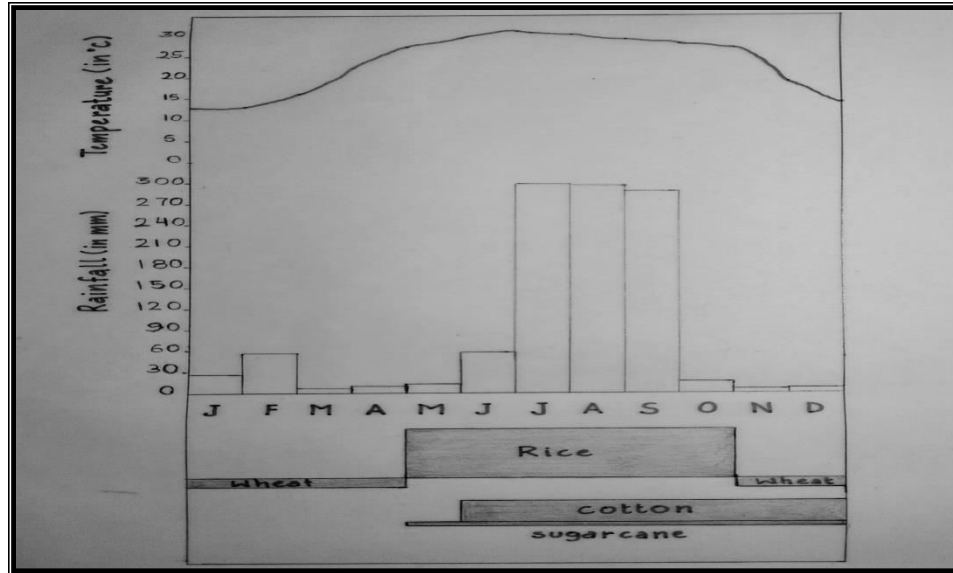

Fig. 4.11 Ergograph of Station A

4.3.8 FLOW LINE DIAGRAMS

In cartography, flow line maps are a type of thematic map drawn to portray the flow or movement of commodities and people across space. These maps or diagrams are drawn to show the direction of objects, goods, and people from one place to another using lines of different widths. These maps show both qualitative and quantitative data. Flow maps help us to understand the flow and pattern of the products transported across space. For example, to show the migration flow, lines are drawn from the country of origin to the destination country, showing volume through different widths of lines.

Flow lines are drawn to show the flow at the national, international, regional, or local level. These can be shown through straight lines or curved lines with or without arrows pointing to the place of origin and destination. The thickness of the lines represents the volume of movement. The flow line maps show two types of data:

- a. The number of goods or passengers to be transported
- b. The number and frequency of the vehicles as per the direction of their movement

The advantages of flow line diagrams are -

- a. They are the only suitable method for portraying the movement of goods.
- b. They are easy to interpret.
- c. They can be used together with other maps and statistical diagrams.

- d. They provide an excellent visual impression.
- e. They are suitable for comparison purposes.
- f. They do not involve complex calculations.

And the disadvantages are –

- a. They take a lot of time to draw.
- b. They hardly provide immediate interpretation.
- c. They are more challenging to draw.
- d. Difficult to plot accurately
- e. Difficult to interpret accurately
- f. Not as intuitive as other data presentation

Construction

Construct flow line diagrams for the following data –

Places	Frequency of Buses from Rohtak
Delhi	151
Gurgaon	37
Sonipat	54
Rewari	28
Bhiwani	82
Jind	98
Hissar	48
Fatehabad	44
Sirsa	41
Chandigarh	32
Ambala	41
Kurukshetra	40
Karnal	49
Ambala	36
Panipat	53
Nainual	19

Steps:

1. Obtain a base map of the required region; here the map of Haryana as we are showing the frequency of buses from Rohtak to different destinations within Haryana and Delhi.
2. Examine the data to determine how thick each flow line will accommodate each flow's magnitude accurately. Here the scale used is 1 cm = 100 buses.
3. Plot the data by drawing lines based on a pre-determined scale. The tail of each line should be at the place of origin and the arrowhead at the destination.

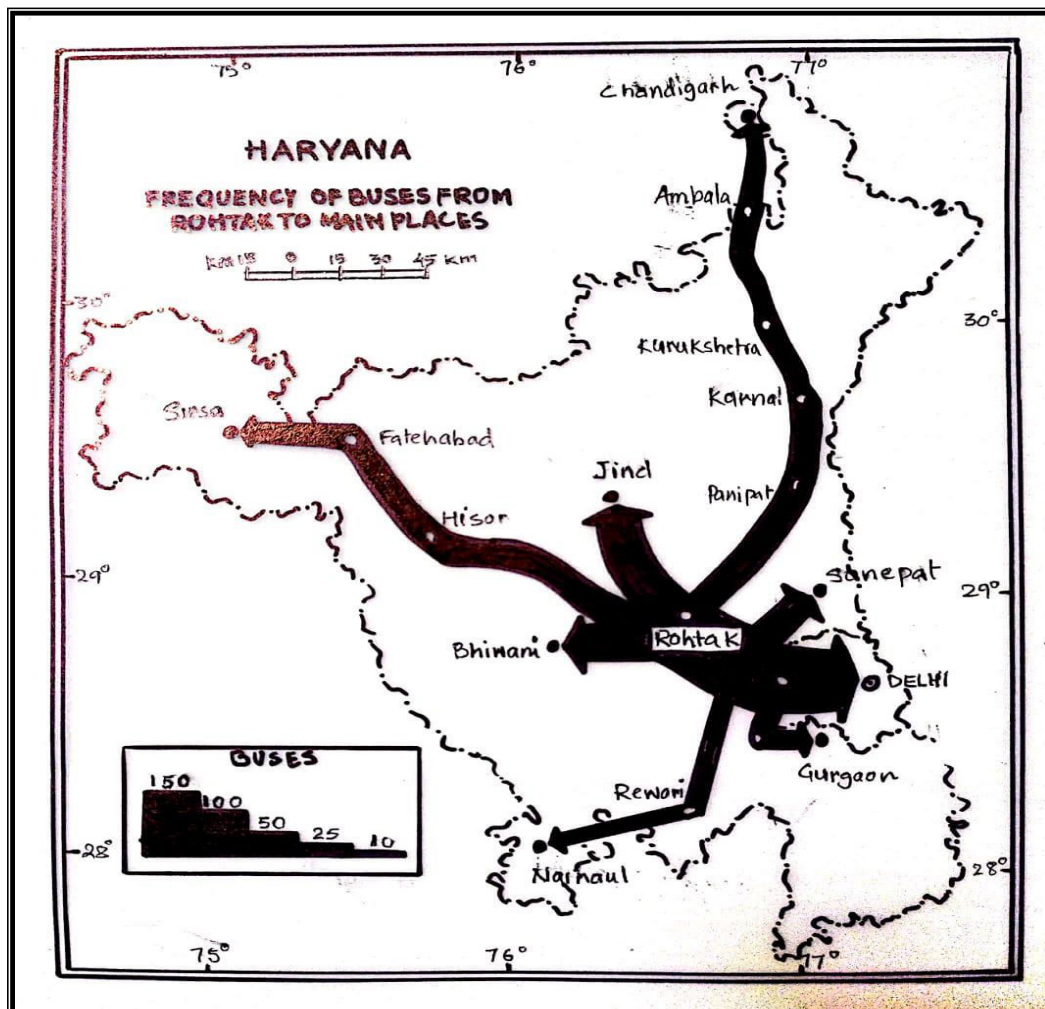

Fig. 4.12 Flow Line diagram showing the frequency of buses from Rohtak to main places

4.4 SUMMARY

In this unit, you have studied how to represent socio-economic data in geographical space. For this purpose, various cartograms have been discussed. These are dots, circles, proportional circle, spheres, proportional squares, choropleth maps, star diagrams, scatter plots, ergographs, and flow line diagrams. Furthermore, the advantages, disadvantages, and construction methods have been discussed here so that you understand which cartogram should be used for which particular socio-economic data.

4.5 GLOSSARY

Cartograms - are diagrammatic maps that can be referred to as the unique representation of geographical space by depicting various attributes graphically.

Dot mapping - A method of cartographic representation to visualize discrete absolute values and their distribution over geographical space.

Ergographs - A graph that shows the relation between the season, climate, and crops of a particular geographical place.

Scatter Diagrams - These are used to investigate the relationship between two variables.

4.6 ANSWER TO CHECK YOUR PROGRESS

1. Define choropleth maps and discuss their advantages and disadvantages.
2. Define Ergograph and discuss its method of construction.
3. Fill in the blanks:
 - a. Dots are placed.
 - b. are called Dorling cartograms.
 - c. The term Ergograph was coined by
 - d. is a three-dimensional diagram.
 - e. Wind rose is an example of diagram.

ANSWER

1. Choropleth Maps are drawn to show data characteristics as they are related to the administrative units. Choropleth is mapping the techniques to symbolize values applied to the area. These maps help to map land-use patterns or types of forest cover. Choropleth maps show the density, literacy, sex ratio, etc. Different interval data are shown through different colour sets. The lighter colour shows low values, whereas the darker colour represents higher values, using single colour shades. Each colour types show a range of values. Choropleth maps are easy to understand and are widely used thematic maps.

The advantages of Choropleth Maps are –

- Give a good visual impression of the data and changes over space
- The patterns can easily be identified.
- Easy to complete

While the disadvantages are -

- It becomes difficult to understand the different colour shades of the values.
- These maps are inappropriate to show total values.
- They show abrupt changes at the boundaries of different colour shaded units
- hides variations within an area
- choropleth maps also suggest that there are sharp contrasts between areas where the boundaries of the maps are drawn (again – not reflective of reality).
- If too many categories, it can be difficult to distinguish between shades.
- Only show the spread of data and not actual amounts.

2. Ergographs are graph that shows the relation between the season, climate and crops. The term ergo means work derived from the Greek word *erogon*. The name Ergograph was coined by Dr. Arthur Geddes. In Ergograph, three elements are shown differently. First, the cultivated area will be demonstrated through the rectangular diagram. Second, rainfall can be shown through a bar graph, whereas line graphs can show temperature or humidity. The steps involved in its construction are –

- i) On x-axis represent 12 months of the year.
- ii) On the y-axis, the rainfall and temperature are represented.
- iii) A suitable scale is selected to represent these two factors.

iv) Temperature is shown through a line graph and rainfall through continuous bars.

v) The net sown area is shown through rectangles at the lower end of the graph. Again, a scale is fixed. The rectangle should be of the proportionate width and cover the months of the growing season,

3. (a) subjectly (b) circles (c) Aurther Geddes (d) Spheres (e) Star

4.7 REFERENCES

<https://gistbok.ucgis.org/bok-topics/flow-maps>

<https://www.bbc.co.uk/bitesize/guides/zyhgqty/revision/3>

<https://sites.google.com/site/skillsa229/flow-lines>

<https://sites.google.com/site/mapcarto1/home/flowline-map>

<https://geographyfieldwork.com/DataPresentationMappingTechniques.htm>

http://www.gitta.info/ThematicCart/en/html/TypogrDesign_learningObject4.html

<https://rashidfaridi.com/2020/04/27/ergograph/>

Patil, Prashant & N.R.Mugade, & M.M.Mane, (2012). An Assessment of Relationship between Crop Production and Climatic Elements: A Case Study of Karveer Tehsil. Indian Journal of Applied research. 1. 104-107. 10.15373/2249555X/JUL2012/34.

4.8 TERMINAL QUESTIONS

1. Define proportional squares.
2. Which type of data is shown through flow line diagrams?
3. Discuss the steps for constructing flow line diagrams.

ANSWERS

1. A proportional square is a cartogram that compares proportions (size, quantities, etc.) to provide a quick overview of the relative size of data without scales. These are two-dimensional diagrams consisting of a series of squares proportional to the quantities they represent.
2. The flow line maps show two types of data:
 - (a) The number of goods or passengers to be transported
 - (b) The number and frequency of the vehicles as per the direction of their movement
3. a) Obtain a base map of the required region.

- b) Examine the data to determine how thick each flow line will accurately accommodate each flow's magnitude.
- c) Plot the data by drawing lines based on a pre-determined scale. The tail of each line should be at the place of origin and the arrowhead at the destination.



UTTARAKHAND OPEN UNIVERSITY

**Teenpani Bypass Road, Behind Transport Nagar,
Haldwani- 263139, Nainital (Uttarakhand)
Phone: 05946-261122, 261123; Fax No. 05946-264232
Website: www.uou.ac.in; e-mail: info@uou.ac.in
Toll Free No.: 1800 180 4025**